



closing the loop on thermal solutions

Industrial Process Thermocouples

INTRODUCTION

Durex Industries manufactures a wide selection of industrial process thermocouples to meet the requirements of the most demanding process applications in the world such as steel processing, turbine and diesel engine temperature measurement, and chemical processing. In addition, Durex Industries also manufactures thermocouples that are built for commercial applications such as for foodservice, packaging, and semiconductor processing. These thermocouples are assembled under rigid quality control standards per ANSI specifications. Durex engineering can assist you with custom designed process thermocouples for your application.

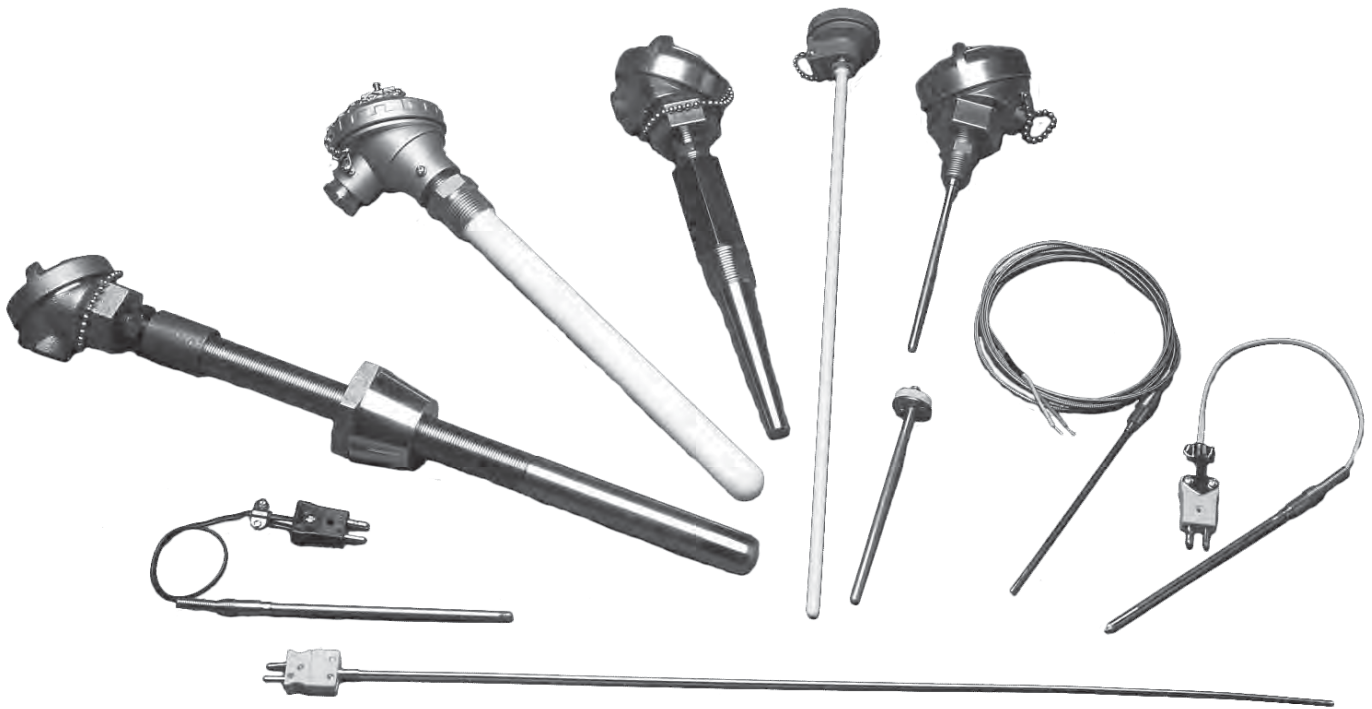

Design Features:

- Various connection and mounting styles available
- Extreme high-temperature ranges
- Capable of handling direct immersion into high pressure or corrosive applications
- Utilized in heavy duty industrial applications
- Ideal for limited space requirements

Typical Applications:

- Steel Processing
- Turbine and Diesel Engine
- Temperature Measurement
- Chemical Processing
- Foodservice
- Packaging
- Semiconductor Processing

THERMOCOUPLE CALIBRATION

Durex offers testing at standard temperatures for determination of initial calibration tolerances for thermocouples. All calibration tests are fully traceable to the National Institute of Standards and Technology (NIST). Calibration is also available for application temperatures other than the standard points in a range from -100°F to 3000°F (-79°C to 1650°C) depending on material. Certificates are supplied for all items calibrated.

Calibration (T/CT type)	Temperatures Available	Applicable Specifications
E, J, K, N, T	32°F to 2300°F (0°C to 1250°C)	ASTM E 207 ASTM E 220
B, R, S	32°F to 3000°F (0°C to 1649°C)	ASTM E 230 ANSI MC 96.1
E, K, N, T	-320°F & -110°F to 23°F (-196°C & -79°C to 0°C)	

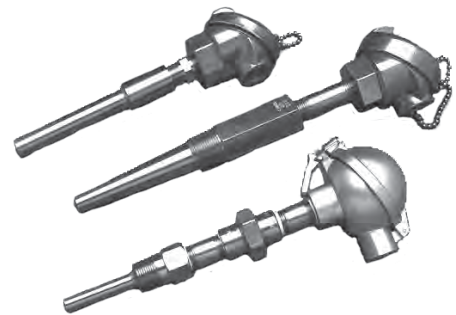

Durex manufactures thermocouple assemblies in the following calibrations:

ANSI Letter	Durex Model Calibration	Calibration Description
Type E	E Chromel P-Constantan®	Standard Limits 32°F to 1652°F (0°C to 900°C) ± 1.7°C or ± 0.5% Tol. Special Limits 32°F to 1652°F (0°C to 900°C) ± 1.0°C or ± 0.4% Tol.
Type J	J Iron - Constantan®	Standard Limits 32°F to 1382°F (0°C to 750°C) ± 2.2°C or ± 0.75% Tol. Special Limits 32°F to 1382°F (0°C to 750°C) ± 1.1°C or ± 0.4% Tol.
Type K	K Chromel P-Alumel®	Standard Limits 32°F to 2282°F (0°C to 1250°C) ± 2.2°C or ± 0.75% Tol. Special Limits 32°F to 2282°F (0°C to 1250°C) ± 1.1°C or ± 0.4% Tol.
Type T	T Copper-Constantan®	Standard Limits 32°F to 662°F (0°C to 350°C) ± 1.0°C or ± 0.75% Tol. Special Limits 32°F to 662°F (0°C to 350°C) ± 0.5°C or ± 0.4% Tol.
Type N	N Nicrosil-NISIL	Standard Limits 32°F to 2282°F (0°C to 1250°C) ± 2.2°C or ± 0.75% Tol. Special Limits 32°F to 2282°F (0°C to 1250°C) ± 1.1°C or ± 0.4% Tol.
Type R	R Pt 13% Rhodium-Platinum	Standard Limits 32°F to 2642°F (0°C to 1450°C) ± 1.5°C or ± 0.25% Tol. Special Limits 32°F to 2642°F (0°C to 1450°C) ± 0.6°C or ± 0.1% Tol.
Type S	S Pt 10% Rhodium-Platinum	Standard Limits 32°F to 2642°F (0°C to 1450°C) ± 1.5°C or ± 0.25% Tol. Special Limits 32°F to 2642°F (0°C to 1450°C) ± 0.6°C or ± 0.1% Tol.
Type B	B Pt 30% Rhodium-Platinum 6% Rhodium	Standard Limits 1598°F to 3092°F (870°C to 1700°C) ± 0.5% Tol.

Industrial Process Thermocouples

JUNCTION TYPES

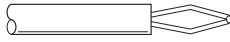

EXPOSED (E)
Joined and welded wires.
Specified where fast response is required.



GROUNDED (G)
Junction is seal welded integrally to the sheath.
Protects wire from corrosive conditions.



UNGROUND (U)
Junction is electrically insulated from seal welded sheath. Design helps prevent stray EMF's.



NECKDOWN (N)
Neckdown provides faster response.
Junction can be single or dual circuit and grounded or ungrounded.

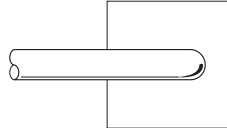

PAD (P)
Pad is designed for welding directly to boiler or process tubes for sensing skin temperatures.

SHEATH DIAMETERS

Sheath Code	T	Y	W	A	B	V	C	D	E	F	H
Sheath Diameter	.020"	.032"	.040"	.062"	.125"	.156"	.188"	.250"	.313"	.375"	.500"
Wire Gauge	38	34	33	30	24	22	20	18	16	15	11
M Length	100'	150'	200'	400'	250'	200'	175'	100'	55'	40'	30'

PART NUMBER CODE DEFINITIONS

L D imensions & U D imensions				"AD imensions		Fractional Dimension Letter Code			
"L" and "U" dimensions are specified in whole inches and use a letter Code for the fraction. (Enter 0 when there is no fraction) Enter the three digit code per examples below:				"A" dimensions are specified in whole inches only. Enter the three digit code as follows:		1/16"	A	11/16"	L
						1/8"	B	3/4"	M
						3/16"	C	13/16"	N
						1/4"	D	7/8"	P
						5/16"	E	15/16"	R
						3/8"	F	1"	S
3"	030	10 5/8"	10K	9"	009	7/16"	G	0	No
4 1/2"	04H	12"	120	12"	012	1/2"	H	Fraction	
6 1/4"	06D	15 3/8"	15F	36"	036	9/16"	J		
7 7/8"	07P	17 3/4"	17M	144"	144	5/8"	K		
9 5/8"	09K	22 1/8"	22B						



closing the loop on thermal solutions

Industrial Process Thermocouples

SPECIFICATIONS

Sheath

Materials: 304 Stainless Steel & Incoloy® 600 are most commonly used. See sheath materials tables on the following pages for the metal types used and their codes. Tolerances: Outside diameter $\pm 0.002''$ of nominal size.

Insulation

High purity magnesium oxide is standard; ultra high purity magnesium oxide and alumina oxide are available.

Formability

Minimum radii: 2X sheath diameter for most thermocouple materials. Consult Durex Industries if special forming is required.

Physical Testing

- Dimensional and visual
- Helium leak
- Radiographic (X-Ray)
- Dye penetration
- Metallurgical per ASTM E-2, E-3, and E-112
- Compaction density per RDT C2-IT

ASTM Testing

Sheathed thermocouple material and sheathed thermocouples are tested using the following specifications:

- ASTM E585 Standard specifications for sheathed based-metal thermocouple materials.
- ASTM E608 Standard specifications for metal-sheathed base-metal thermocouples.
- ASTM E780 Standard method for measuring the insulation resistance of sheathed thermocouple-material at room temperature.
- ASTM E839 Standard test methods for sheathed thermocouples and sheathed thermocouple material.

Insulation Resistance

Nominal Sheath Outside Diameter	Applied D.C. V oltg e(min)	Insulation Resistance Meg Ω
.030" Diameter and smaller	50	100
.030" to .059" Diameter	50	500
.062" Diameter and larger	500	1000

Finish

Bright annealed, 32 micro-inch or better.

Configurations

Sheath diameters available from 0.020" to 0.500". Two wire (single circuit) and four wire (double circuit) configurations are standard in most diameters.

Weldability

Thermocouple sheath can be brazed, soldered, or welded without loss of insulation resistance. Welding of special sheath materials by the customer is not recommended.

Electrical Testing

- Calibration per ASTM E-220 traceable to NIST
- Insulation resistance
- Wire resistance (ohms per foot loop)
- Time response per RDT C2-3T
- Thermal cycling per ASTM E-225

Industrial Process Thermocouples

SHEATHED MgO THERMOCOUPLE ASSEMBLY WITH STRIPPED END

The TDC2 Style Thermocouple features an MgO insulated element which is junctioned and terminated with a standard 1" long strip. This style is designed for field replacement or addition of other termination options.

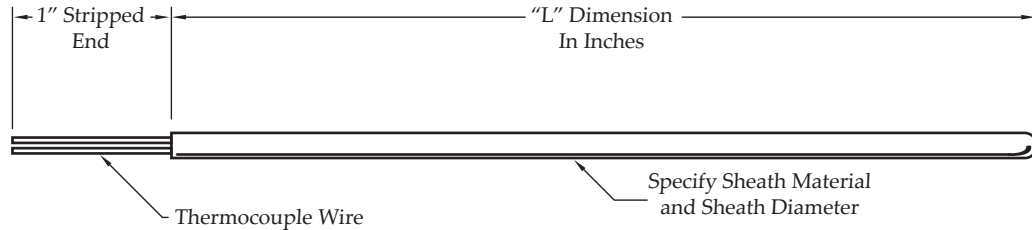

STYLE TDC2 - Stripped End MgO Thermocouple

Table 1: Thermocouple Type

Thermocouple Type Codes				Limits of Error
E	J	K	T	Standard Limits
2	3	4	8	Special Limits

Table 2: Junction Type

Code	Single Junction	Code	Dual Junction
G	Grounded	H	Grounded
U	Ungrounded	L	Ungrounded Isolated
C	Exposed	V	Ungrounded Common
		W	Exposed

Table 3: Sheath Material

Code	Material Type
1	310 Stainless Steel
2	321 Stainless Steel
3	330 Stainless Steel
4	304 Stainless Steel
5	446 Stainless Steel
6	316 Stainless Steel
7	347 Stainless Steel
8	Inconel® 600 (Alloy 600)
A	Alloy 601

Table 4: Sheath Diameter

Code	O.D. Size
T	.020" O.D.
Y	.032" or 1/32" O.D.
W	.040" O.D.
A	.062" or 1/16" O.D.
B	.125" or 1/8" O.D.
V	.156" or 5/32" O.D.
C	.188" or 3/16" O.D.
D	.250" or 1/4" O.D.
E	.313" or 5/16" O.D.
F	.375" or 3/8" O.D.
H	.500" or 1/2" O.D.

Table 5: Dimension

Specify in inches. See table on page 27 for codes.

Part Number Sequence

TDC2-JG-4F100

TDC2	-	J	G	-	4	F	100
TDC2		Table 1	Table 2		Table 3	Table 4	Table 5
Sensor Type & Style No.		Thermocouple Type	Junction Type		Sheath Material	Sheath Diameter	"L" Dimension

Industrial Process Thermocouples

SHEATHED MgO THERMOCOUPLE ASSEMBLY WITH PLUG

The TDC3 Style Thermocouple features an MgO insulated element with universal disconnect plug for reliable connections. Plugs are available in standard (400°F), high temperature (800°F), and ceramic (1200°F) materials.

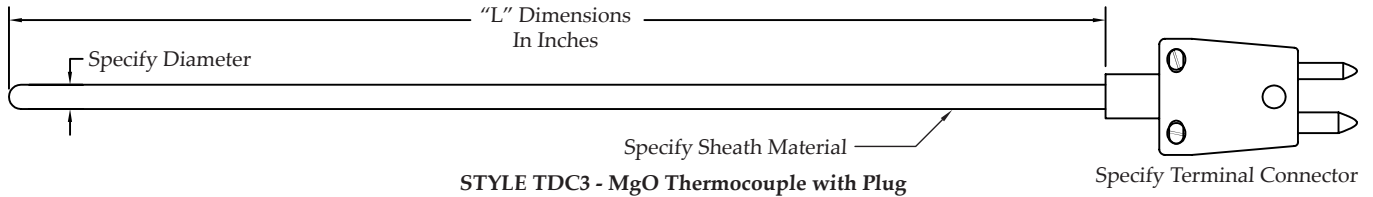

STYLE TDC3 - MgO Thermocouple with Plug

Specify Terminal Connector

Table 1: Thermocouple Type

Thermocouple Type Codes				Limits of Error
E	J	K	T	Standard Limits
2	3	4	8	Special Limits

Table 2: Junction Type

Code	Single Junction	Code	Dual Junction
G	Grounded	H	Grounded
U	Ungrounded	L	Ungrounded Isolated
C	Exposed	V	Ungrounded Common
		W	Exposed

Table 3: Sheath Material

Code	Material Type
1	310 Stainless Steel
2	321 Stainless Steel
3	330 Stainless Steel
5	446 Stainless Steel
6	316 Stainless Steel
7	347 Stainless Steel
8	Inconel® 600 (Alloy 600)
A	Alloy 601

Table 4: Sheath Diameter

Code	O.D. Size
T	.020" O.D.
Y	.032" or 1/32" O.D.
W	.040" O.D.
A	.062" or 1/16" O.D.
B	.125" or 1/8" O.D.
V	.156" or 5/32" O.D.
C	.188" or 3/16" O.D.
D	.250" or 1/4" O.D.
E	.313" or 5/16" O.D.
F	.375" or 3/8" O.D.
H	.500" or 1/2" O.D.

Table 5: Dimension

Specify in inches. See table on page 27 for codes.

Table 6: Terminal Connector

Code	Terminal Connector
3	Standard Molded Plug
6	Standard Plug with Brazing Adapter
7	Standard Plug with Tube Adapter
8	High Temperature Plug with Crimp Adapter
9	Ceramic Plug with Tube Adapter
F	Mini Molded Plug
M	Mini Plug with Crimp Adapter
X	Special, Specify

Part Number Sequence

TDC3-JG-4F12F-3

TDC3	-	J	G	-	4	F	12F	-	3
TDC3		Table 1	Table 2		Table 3	Table 4	Table 5		Table 6
Sensor Type & Style No.		Thermocouple Type	Junction Type		Sheath Material	Sheath Diameter	"L" Dimension		Terminal Connector

Industrial Process Thermocouples

SHEATHED MgO THERMOCOUPLE ASSEMBLY WITH PROCESS HEAD

The TDC4 Style Thermocouple features an MgO insulated element with a protective terminal housing and process connector. This style can be manufactured as spring loaded for direct field replacement into existing thermowells.

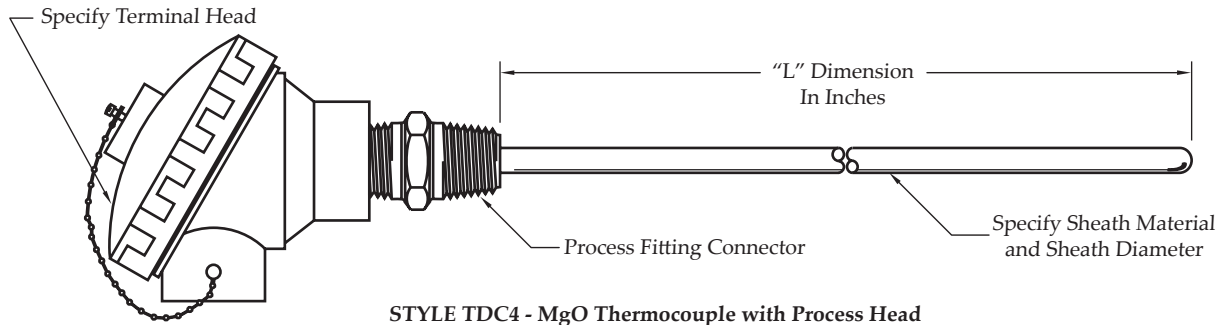

STYLE TDC4 - MgO Thermocouple with Process Head

Table 1: Thermocouple Type

Thermocouple Type Codes				Limits of Error
E	J	K	T	Standard Limits
2	3	4	8	Special Limits

Table 2: Junction Type

Code	Single Junction	Code	Dual Junction
G	Grounded	H	Grounded
U	Ungrounded	L	Ungrounded Isolated
C	Exposed	V	Ungrounded Common
		W	Exposed

Table 5: Sheath Material

Code	Material Type
1	310 Stainless Steel
2	321 Stainless Steel
4	304 Stainless Steel
5	446 Stainless Steel
6	316 Stainless Steel
7	347 Stainless Steel
8	Inconel® 600 (Alloy 600)
A	Alloy 601

Table 6: Sheath Diameter

Code	O.D. Size
T	.020" O.D.
Y	.032" or 1/32" O.D.
W	.040" O.D.
A	.062" or 1/16" O.D.
B	.125" or 1/8" O.D.
V	.156" or 5/32" O.D.
C	.188" or 3/16" O.D.
D	.250" or 1/4" O.D.
E	.313" or 5/16" O.D.
F	.375" or 3/8" O.D.
H	.500" or 1/2" O.D.

Table 7: Dimension

Specify in inches. See table on page 27 for codes.

Table 7: Spring Loaded Option

Code	Probe Style
1	Fixed
2	Spring Loaded

Table 8: Screw Cover Terminal Heads

Code	Screw Cover Head Materials
A	1/2" NPT Conduit, Aluminum Head
B	3/4" NPT Conduit, Aluminum Head
C	1/2" NPT Conduit, Cast Iron Head
D	3/4" NPT Conduit, Cast Iron Head
M	1/4" NPT Conduit Connection, Miniature Plastic Head
P	1/2" NPT Conduit, Grey Delrin Head
R	3/4" NPT Conduit, Grey Delrin Head
W	1/2" NPT Conduit, White Polypropylene Head
V	3/4" NPT Conduit, White Polypropylene Head
Z	1/2" NPT Conduit, Explosion Proof Aluminum Head
Y	3/4" NPT Conduit, Explosion Proof Aluminum Head

Table 6: Fitting Options

Code	Process Size
0	No Process Connection
6	1/2" NPT Stainless Steel Hex Nipple
8	3/4" NPT Stainless Steel Hex Nipple
G	1/2" NPT Brass Hex Bushing
H	1/2" NPT Stainless Steel Hex Bushing

Part Number Sequence TDC4-JG-6C060-61A0

TDC4	-	J	G	-	6	C	060	-	6	1	A	0
TDC4		Table 1	Table 2	Table 3	Table 4	Table 5	Table 6	Table 7	Table 8	Table 6		
Sensor Type & Style No.		Thermocouple Type	Junction Type	Sheath Material	Sheath Diameter	"L" Dimension	Fitting Options Into Head	Spring Loaded Option	Terminal Heads	Fitting Options On Probe		

Industrial Process Thermocouples

SHEATHED MgO THERMOCOUPLE ASSEMBLY WITH OPEN TERMINAL DISC

The TDC5 Style Thermocouple features an MgO insulated element with an open terminal disc design. This design allows greater accessibility in wiring for space restricted areas.

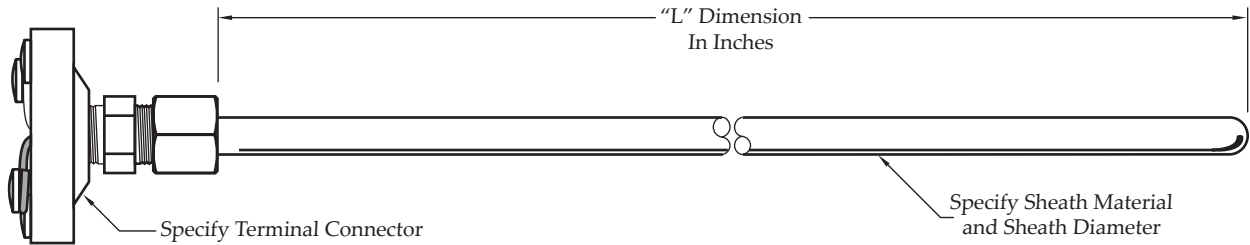

STYLE TDC5 - MgO Thermocouple with Open Terminal Disc

Table 1: Thermocouple Type

Thermocouple Type Codes				Limits of Error
E	J	K	T	Standard Limits
2	3	4	8	Special Limits

Table 2: Junction Type

Code	Single Junction	Code	Dual Junction
G	Grounded	H	Grounded
U	Ungrounded	L	Ungrounded Isolated
C	Exposed	V	Ungrounded Common
		W	Exposed

Table 3: Sheath Material

Code	Material Type
1	310 Stainless Steel
2	321 Stainless Steel
4	304 Stainless Steel
5	446 Stainless Steel
6	316 Stainless Steel
7	347 Stainless Steel
8	Inconel® 600 (Alloy 600)
A	Alloy 601

Table 4: Sheath Diameter

Code	O.D. Size
T	.020" O.D.
Y	.032" or 1/32" O.D.
W	.040" O.D.
A	.062" or 1/16" O.D.
B	.125" or 1/8" O.D.
V	.156" or 5/32" O.D.
C	.188" or 3/16" O.D.
D	.250" or 1/4" O.D.
E	.313" or 5/16" O.D.
F	.375" or 3/8" O.D.
H	.500" or 1/2" O.D.

Table 5: Dimension

Specify in inches. See table on page 27 for codes.

Table 6: Terminal Connector

Code	Terminal Style
J	Circular Terminal Block, Ceramic
K	Circular Terminal Block, Glass Cloth
X	Special, Specify

Part Number Sequence

TDC5-KG-4D09D-K

TDC5	-	K	G	-	4	D	09D	-	K
TDC5		Table 1	Table 2		Table 3	Table 4	Table 5		Table 6
Sensor Type & Style No.		Thermocouple Type	Junction Type		Sheath Material	Sheath Diameter	"L" Dimension		Terminal Connector

Industrial Process Thermocouples

SHEATHED MgO THERMOCOUPLE ASSEMBLY WITH INSULATED LEADWIRE

The TDC6 Style Thermocouple features an MgO insulated element that is terminated to an insulated extension wire. An optional terminal connector can be added to the extension wire.

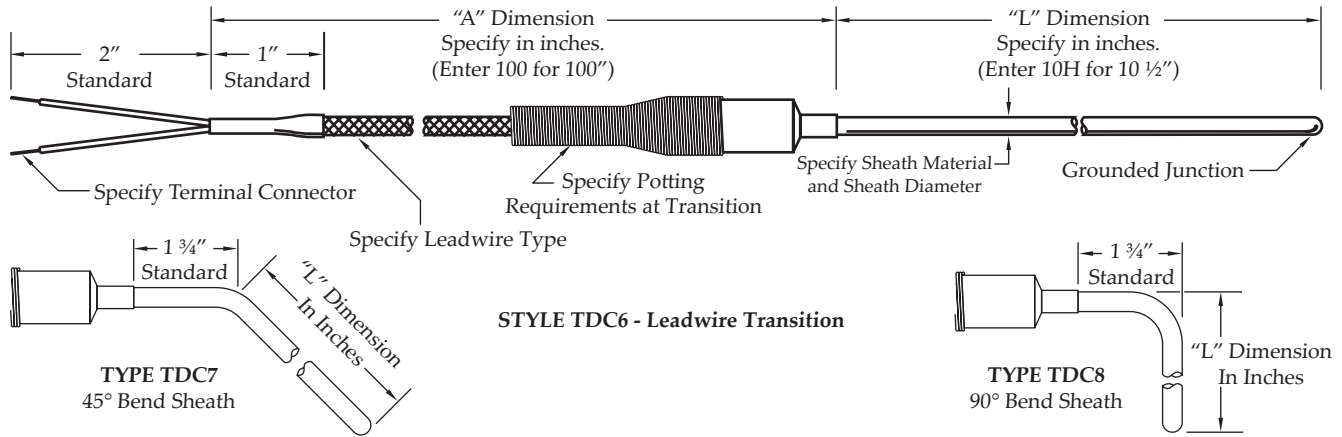

Table 1: Thermocouple Type

Thermocouple Type Codes				Limits of Error
E	J	K	T	Standard Limits
2	3	4	8	Special Limits

Table 2: Junction Type

Code	Single Junction	Code	Dual Junction
G	Grounded	H	Grounded
U	Ungrounded	L	Ungrounded Isolated
C	Exposed	V	Ungrounded Common
		W	Exposed

Table 3: Sheath Material

Code	Material Type
1	310 Stainless Steel
2	321 Stainless Steel
4	304 Stainless Steel
5	446 Stainless Steel
6	316 Stainless Steel
7	347 Stainless Steel
8	Inconel® 600 (Alloy 600)
A	Alloy 601

Table 4: Sheath Diameter

Code	O.D. Size
T	.020" O.D.
Y	.032" or 1/32" O.D.
W	.040" O.D.
A	.062" or 1/16" O.D.
B	.125" or 1/8" O.D.
V	.156" or 5/32" O.D.
C	.188" or 3/16" O.D.
D	.250" or 1/4" O.D.
E	.313" or 5/16" O.D.
F	.375" or 3/8" O.D.
H	.500" or 1/2" O.D.

Table 5: D dimension

Specify in inches. See table on page 27 for codes.

Table 6: AD dimension

Specify in inches. See table on page 27 for codes.

Table 7: Leadwire Type & Construction

Insulation Type	Conductor Type	Standard	Stainless Steel Overbraid	Stainless Steel Armor
Fiberglass	Solid	A	B	C
Teflon	Solid	D	E	F
Fiberglass	Stranded	G	H	J
Teflon	Stranded	K	L	M
Kapton	Solid	N	P	Q
PVC	Solid	R	S	T
PVC	Stranded	W	Y	Z

Table 8: Terminal Connector

Code	Terminal Style
0	Split Leads, 2" Length Standard
1	3/16" Spade Lugs
3	Standard Plug
4	Standard Jack
M	Mini Plug
N	Mini Jack
X	Special, Specify

Table 9: Potting Requirements

Code	Maximum Temperatures
L	500°F
M	1000°F

Part Number Sequence TDC6-TG-6D08M-024C0M

TDC6	-	T	G	-	6	D	08M	-	024	C	0	M
TDC6		Table 1	Table 2	Table 3	Table 4	Table 5	Table 6	Table 7	Table 8	Table 9		

Sensor Type Thermocouple Junction Sheath Sheath "L" "A" Leadwire Terminal Potting & Style No. Type Type Material Diameter Dimension Dimension Construction Connector Requirements

Industrial Process Thermocouples

SHEATHED MgO MINI THERMOCOUPLE ASSEMBLY WITH MOLDED TRANSITION

The TDC9 Style Thermocouple features an MgO insulated element that is terminated to an insulated extension wire and encapsulated in a plastic injection molded "mini" transition using insert mold technology and a Liquid Crystal Polymer. Transition can withstand continuous exposure to temperatures up to 562°F.

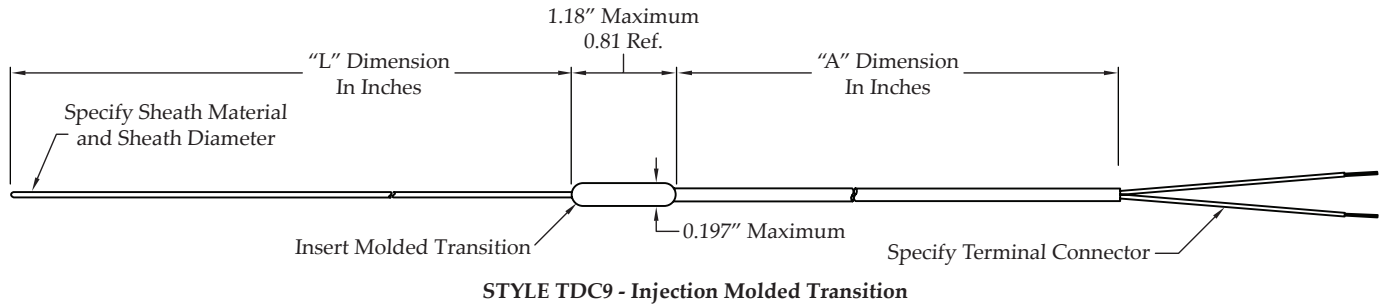

Table 1: Thermocouple Type

Thermocouple Type Codes				Limits of Error
E	J	K	T	Standard Limits
2	3	4	8	Special Limits

Table 2: Junction Type

Code	Single Junction
G	Grounded
U	Ungrounded
C	Exposed

Table 3: Sheath Material

Code	Material Type
4	304 Stainless Steel
6	316 Stainless Steel
8	Inconel® 600 (Alloy 600)

Table 4: Sheath Diameter

Code	O.D. Size
T	.020" O.D.
Y	.032" or 1/32" O.D.
W	.040" O.D.
A	.062" or 1/16" O.D.
X	Special, Specify

Table 5: Sheath Dimension

Specify in inches. See table on page 27 for codes.

Table 6: Sheath AD Dimension

Specify in inches. See table on page 27 for codes.

Table 7: Leadwire Type & Construction

Insulation Type	Conductor Type	Standard
Fiberglass	Solid	A
Teflon	Solid	D
Fiberglass	Stranded	G
Teflon	Stranded	K
Kapton	Solid	N

Table 8: Terminal Connector

Code	Terminal Connector Style
0	Split Leads, 2" Length Standard
1	#6 Spade Lugs
3	Standard Plug
4	Standard Jack
X	Special, Specify

Part Number Sequence TDC9-TG-6T08M-024A0L

TDC9	-	T	G	-	6	T	08M	-	024	A	0
TDC9		Table 1	Table 2	Table 3	Table 4	Table 5	Table 6	Table 7	Table 8		
Sensor Type & Style No.		Thermocouple Type	Junction Type	Sheath Material	Sheath Diameter	"L" Dimension	"A" Dimension	Leadwire Construction	Terminal Connector		

Industrial Process Thermocouples

THERMOCOUPLE WITH THREADED THERMOWELL

The TDW1 and TDW2 Style Thermocouple assemblies feature a thermocouple element protected by a drilled bar stock thermowell. Various well materials and terminal heads are available as options. See next page for well selections.

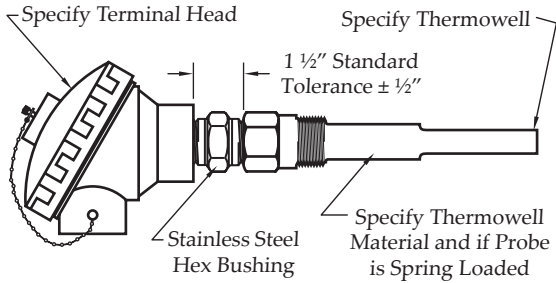

STYLE TDW1 - Nipple, Thermowell Assembly

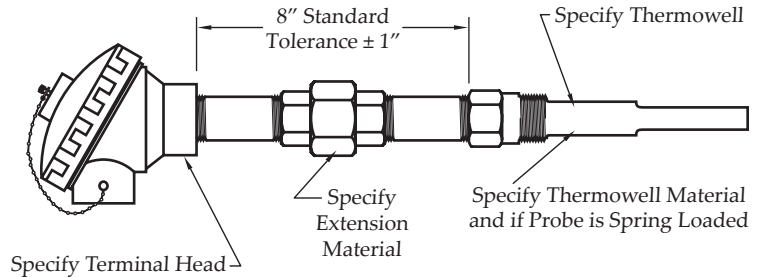

STYLE TDW2 - Nipple, Union, Nipple, Thermowell Assembly

Table 1: Thermocouple Type

Thermocouple Type Codes				Limits of Error
E	J	K	T	Standard Limits
2	3	4	8	Special Limits

Table 2: Element Type

Code	Material Type
O	MI Cable, 18 Gauge, Single, Specify Junction GND/UNG
P	MI Cable, 18 Gauge, Dual, Specify Junction GND/UNG

Table 3: Well Material

Code	Material Type
4	304 Stainless Steel
6	316 Stainless Steel
B	Brass
R	Carbon Steel

Table 4: Extension Material (TDW2 Only)

Code	Nipple Material
K	Black Pipe, Schedule 40
Y	Galvanized Steel
4	304 Stainless Steel
6	316 Stainless Steel

Table 5: Spring Loaded Option

Code	Probe Style
1	Fixed Fitting
2	Spring Loaded Fitting

Table 6: Screw Cover Terminal Heads

Code	Screw Cover Head Materials
A	1/2" NPT Conduit, Aluminum Head
B	3/4" NPT Conduit, Aluminum Head
C	1/2" NPT Conduit, Cast Iron Head
D	3/4" NPT Conduit, Cast Iron Head
M	1/4" NPT Conduit Connection, Miniature Plastic Head
P	1/2" NPT Conduit, Grey Delrin Head
W	1/2" NPT Conduit, White Polypropylene Head
Z	1/2" NPT Conduit, Explosion Proof Aluminum Head
Y	3/4" NPT Conduit, Explosion Proof Aluminum Head

Part Number Sequence

TDW2-KP-1207H6-Y1A

TDW2	-	K	P	-	1207H	6	-	Y	1	A
TDW2		Table 1	Table 2		See next page	Table 3		Table 4	Table 5	Table 6
Sensor Type & Style No.		Thermocouple Type	Element Type		Thermowell Number	Well Material		Extension Material	Spring Loaded Option	Terminal Heads

THERMOWELL STYLES

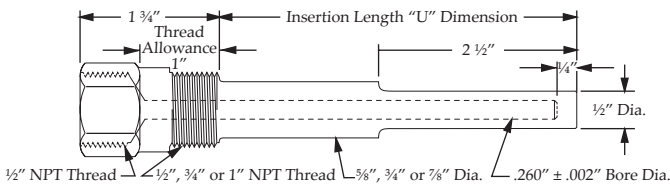

Standard Well - Stepped Shank

U D im.	1/2" N PT	3/4" N PT	N PT
2 1/2"	1202H	1302H	1402H
4 1/2"	1204H	1304H	1404H
6"	12060	13060	14060
7 1/2"	1207H	1307H	1407H
10 1/2"	1210H	1310H	1410H
12"	12120	13120	14120
16 1/2"	1216H	1316H	1416H
22 1/2"	1222H	1322H	1422H

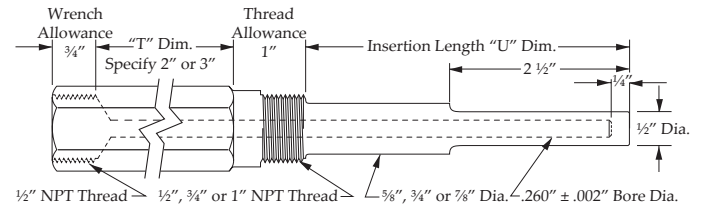

Lagging Extension Well - Stepped Shank

U D im.	1/2" N PT	3/4" N PT	N PT
2 1/2"	2202H	2302H	2402H
4 1/2"	2204H	2304H	2404H
6"	22060	23060	24060
7 1/2"	2207H	2307H	2407H
10 1/2"	2210H	2310H	2410H
12"	22120	23120	24120
16 1/2"	2216H	2316H	2416H
22 1/2"	2222H	2322H	2422H

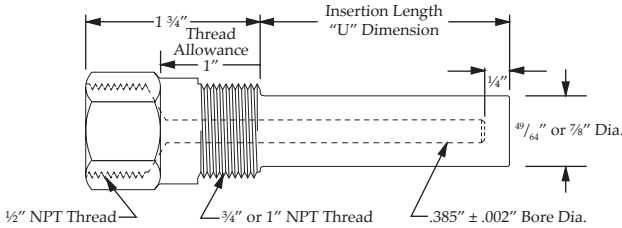

Standard Well - Straight Shank

U D im.	3/4" N PT	N PT
2 1/2"	3302H	3402H
4 1/2"	3304H	3404H
6"	33060	34060
7 1/2"	3307H	3407H
10 1/2"	3310H	3410H
12"	33120	34120
16 1/2"	3316H	3416H
22 1/2"	3322H	3422H

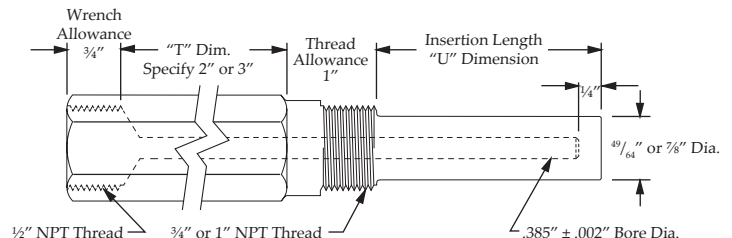

Lagging Extension Well - Straight Shank

U D im.	3/4" N PT	N PT
2 1/2"	4302H	4402H
4 1/2"	4304H	4404H
6"	43060	44060
7 1/2"	4307H	4407H
10 1/2"	4310H	4410H
12"	43120	44120
16 1/2"	4316H	4416H
22 1/2"	4322H	4422H

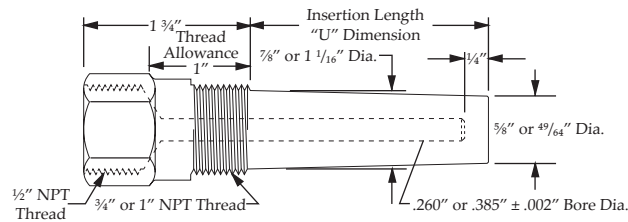

Standard Well - Tapered Shank

U D im.	3/4" N PT		N PT	
	.260" Bore	B ore	.260" Bore	B ore
2 1/2"	5302H	6302H	5402H	6402H
4 1/2"	5304H	6304H	5404H	6404H
6"	53060	63060	54060	64060
7 1/2"	5307H	6307H	5407H	6407H
10 1/2"	5310H	6310H	5410H	6410H
12"	53120	63120	54120	64120
16 1/2"	5316H	6316H	5416H	6416H
22 1/2"	5322H	6322H	5422H	6422H

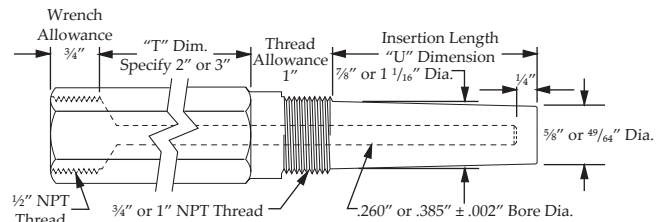

Lagging Extension Well - Tapered Shank

U D im.	3/4" N PT		N PT	
	.260" Bore	B ore	.260" Bore	B ore
2 1/2"	7302H	8302H	7402H	8402H
4 1/2"	7304H	8304H	7404H	8404H
6"	73060	83060	74060	84060
7 1/2"	7307H	8307H	7407H	8407H
10 1/2"	7310H	8310H	7410H	8410H
12"	73120	83120	74120	84120
16 1/2"	7316H	8316H	7416H	8416H
22 1/2"	7322H	8322H	7422H	8422H

Industrial Process Thermocouples

THERMOCOUPLE WITH FLANGED THERMOWELL

The TDW3 and TDW4 Style Thermowell assemblies feature a thermocouple element protected by a flanged thermowell. Various well materials, flange materials, and sizes are available. See next page for well selection.

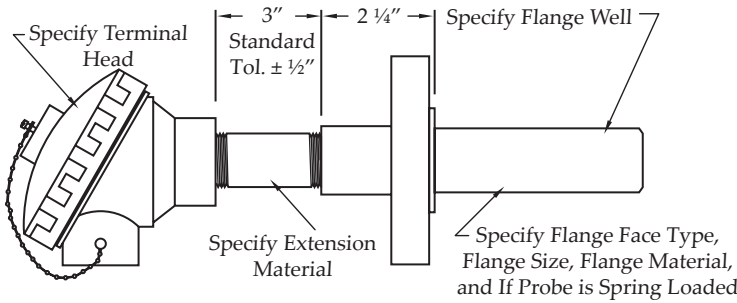

STYLE TDW3 - Fixed Flange Well

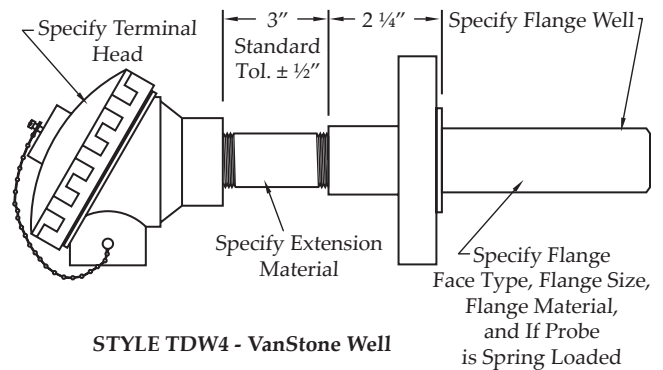

STYLE TDW4 - VanStone Well

Table 1: Thermocouple Type

Thermocouple Type Codes				Limits of Error
E	J	K	T	Standard Limits
2	3	4	8	Special Limits

Table 2: Element Type

Code	Material Type
O	MI Cable, 18 Gauge, Single, Specify Junction GND/UNG
P	MI Cable, 18 Gauge, Dual, Specify Junction GND/UNG

Table 3: Flange Face Type

Code	Face Type
1	Raised Face
2	Flat Face

Table 4: Flange Size

Code	Flange Size (TDW3 Only)
D	1 1/2" Flange
E	2" Flange
F	2 1/2" Flange
G	3" Flange
H	4" Flange

Table 5: Well Material

Code	Material Type
4	304 Stainless Steel
6	316 Stainless Steel
B	Brass
R	Carbon Steel

Table 6: Extension Material

Code	Nipple Material
K	Black Pipe, Schedule 40
Y	Galvanized Steel
4	304 Stainless Steel
6	316 Stainless Steel

Table 7: Spring Loaded Option

Code	Probe Style
1	Fixed Fitting
2	Spring Loaded Fitting

Table 8: Screw Cover Terminal Heads

Code	Screw Cover Head Materials
A	1/2" NPT Conduit, Aluminum Head
B	3/4" NPT Conduit, Aluminum Head
C	1/2" NPT Conduit, Cast Iron Head
D	3/4" NPT Conduit, Cast Iron Head
Z	1/2" NPT Conduit, Explosion Proof Aluminum Head
Y	3/4" NPT Conduit, Explosion Proof Aluminum Head

Part Number Sequence TDW3-JP-F410701E4K1A

TDW3	-	J	P	-	F41070	1	E	4	K	1	A
TDW3		Table 1	Table 2	See next page	Table 3	Table 4	Table 5	Table 6	Table 7	Table 8	

Sensor Type Thermocouple Element Thermowell Flange Flange Well Extension Spring Loaded Terminal & Style No. Type Type Number Face Type Size Material Material Option Heads

FLANGED THERMOWELL STYLES

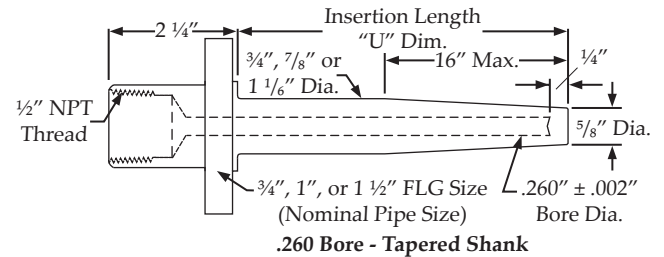
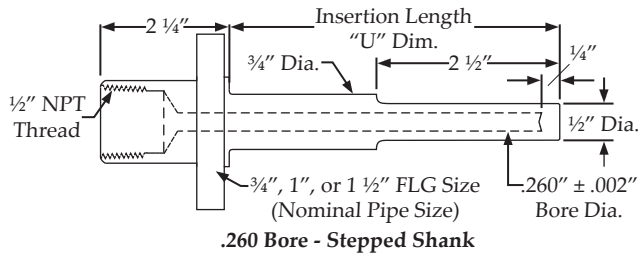

U D im.	3/4" LGS in	1" LGS in	1 1/2" LGS in
4"	F11040	F12040	F13040
7"	F11070	F12070	F13070
10"	F11100	F12100	F13100
13"	F11130	F12130	F13130
16"	F11160	F12160	F13160
22"	F11220	F12220	F13220

U D im.	3/4" LGS in	1" LGS in	1 1/2" LGS in
4"	F51040	F52040	F53040
7"	F51070	F52070	F53070
10"	F51100	F52100	F53100
13"	F51130	F52130	F53130
16"	F51160	F52160	F53160
22"	F51220	F52220	F53220

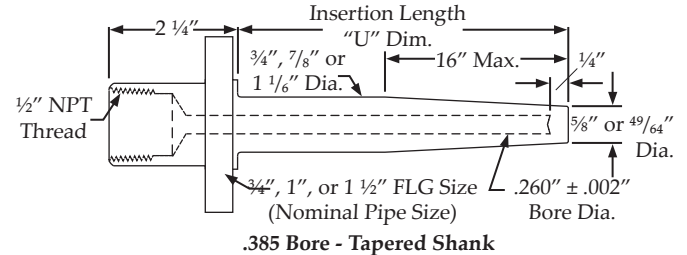
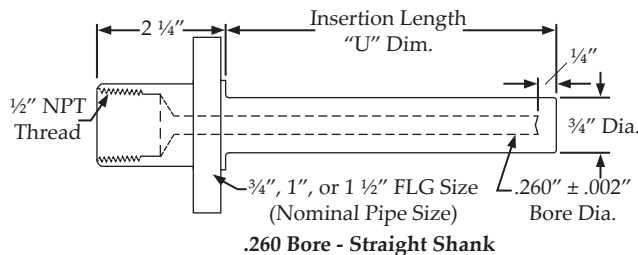

U D im.	3/4" LGS in	1" LGS in	1 1/2" LGS in
4"	F31040	F32040	F33040
7"	F31070	F32070	F33070
10"	F31100	F32100	F33100
13"	F31130	F32130	F33130
16"	F31160	F32160	F33160
22"	F31220	F32220	F33220

U D im.	3/4" LGS in	1" LGS in	1 1/2" LGS in
4"	F61040	F62040	F63040
7"	F61070	F62070	F63070
10"	F61100	F62100	F63100
13"	F61130	F62130	F63130
16"	F61160	F62160	F63160
22"	F61220	F62220	F63220

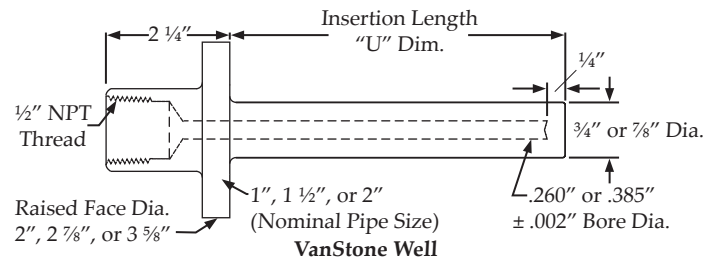
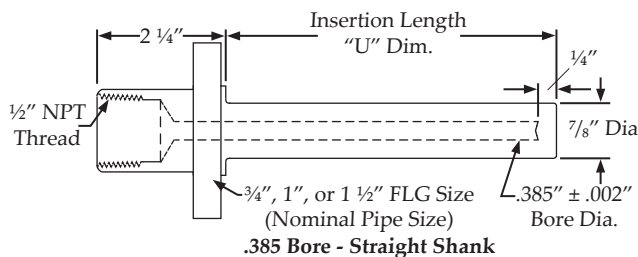

U D im.	3/4" LGS in	1" LGS in	1 1/2" LGS in
4"	F41040	F42040	F43040
7"	F41070	F42070	F43070
10"	F41100	F42100	F43100
13"	F41130	F42130	F43130
16"	F41160	F42160	F43160
22"	F41220	F42220	F43220

	U D im.	1" NPS	1 1/2" PS	2" PS
	.260 Bore	4"	F81040	F82040
	7"	F81070	F82070	F83070
	10"	F81100	F82100	F83100
	13"	F81130	F82130	F83130
	16"	F81160	F82160	F83160
	22"	F81220	F82220	F83220
.385 Bore	4"	F91040	F92040	F93040
	7"	F91070	F92070	F93070
	10"	F91100	F92100	F93100
	13"	F91130	F92130	F93130
	16"	F91160	F92160	F93160
	22"	F91220	F92220	F93220

Industrial Process Thermocouples

BASE METAL PROTECTION TUBE ASSEMBLY

The TPT Style Thermocouple assemblies feature a base metal thermocouple and metal protection tube for use in corrosive or hostile environments. Optional mounting bushings and flanges are available.

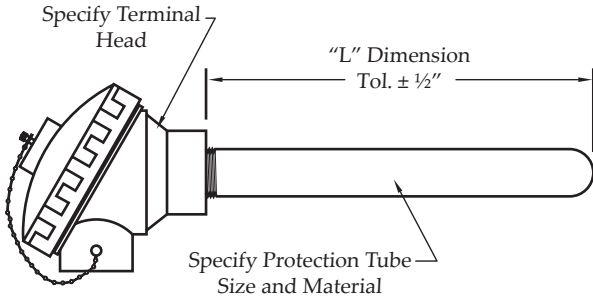

STYLE TPT - Metal Protection Tube

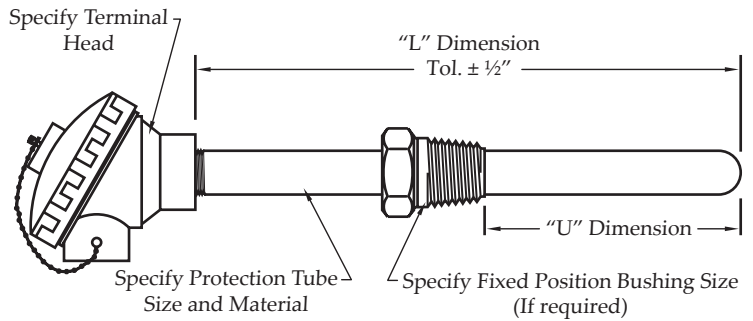

STYLE TPB - Metal Protection Tube with Process Bushing

Table 1: Thermocouple Type

Thermocouple Type Codes				Limits of Error
E	J	K	T	Standard Limits
2	3	4	8	Special Limits

Table 3: Protection Tube Size

Code	IPS (Nominal)
H	3/8" (.675)
L	1/2" (.840)
M	3/4" (1.050)
N	1" (1.315)
O	1 1/4" (1.660)
P	1 1/2" (1.900)

Table 4: Wall Thickness

Code	Nominal Wall
W	Schedule 40
Y	Schedule 80
Z	Schedule 160

Table 5: Dimension

Specify in inches. See table on page 27 for codes.

Table 8: Fitting Options

Code	Description
0	No fitting option
E	1/2" NPT Hex Bushing
F	3/4" NPT Hex Bushing
X	Special

Table 9: Fitting Material

Code	Description
4	304 Stainless Steel
6	316 Stainless Steel
B	Brass
R	Steel

Table 7: Element Type

Code	Material Type
L	Beaded, 8 Gauge, Single, Specify Junction
M	Beaded, 14 Gauge, Single, Specify Junction
N	Beaded, 14 Gauge, Dual, Specify Junction
O	MI Cable, 18 Gauge, Single, Specify Junction GND/UNG
P	MI Cable, 18 Gauge, Dual, Specify Junction GND/UNG

Table 6: Dimension

Specify in inches. See table on page 27 for codes.

Table 10: Protection Tube Materials

Code	Material
4	304 Stainless Steel
6	316 Stainless Steel
8	Inconel® 600
A	Inconel® 601
R	Carbon Steel

Table 10: Screw Cover Terminal Heads

Code	Screw Cover Head Materials
A	1/2" NPT Conduit, Aluminum Head
B	3/4" NPT Conduit, Aluminum Head
C	1/2" NPT Conduit, Cast Iron Head
D	3/4" NPT Conduit, Cast Iron Head
M	1/4" NPT Conduit Connection, Miniature Plastic Head
P	1/2" NPT Conduit, Grey Delrin Head
W	1/2" NPT Conduit, White Polypropylene Head
Z	1/2" NPT Conduit, Explosion Proof Aluminum Head
Y	3/4" NPT Conduit, Explosion Proof Aluminum Head

Part Number Sequence

TPT-EN-LW07H4-10F6A

TPT	-	E	N	-	L	W	07H	4	-	10H	F	6	A
TPT		Table 1	Table 2	Table 3	Table 4	Table 5	Table 6	Table 7	Table 8 & 9	Table 10			
Sensor Type & Style No.		Thermocouple Type	Element Type	Tube Size	Wall Thickness	"U" Dimension	Tube Material	"L" Dimension	Process Fitting	Terminal Heads			

Industrial Process Thermocouples

BASE METAL CERAMIC PROTECTION TUBE ASSEMBLY

The TPTC Style Thermocouple assemblies feature a base metal thermocouple element and ceramic protection tube for high temperature service. Ceramic mounting bushings are available.

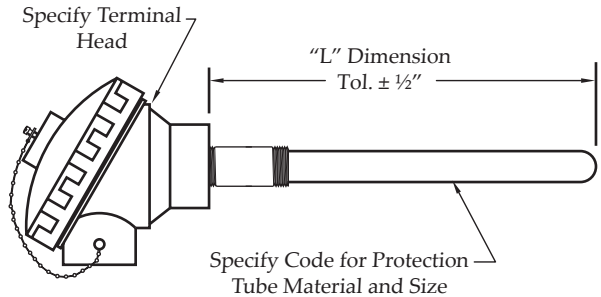

STYLE TPTC - Ceramic Protection Tube with Pipe Nipple

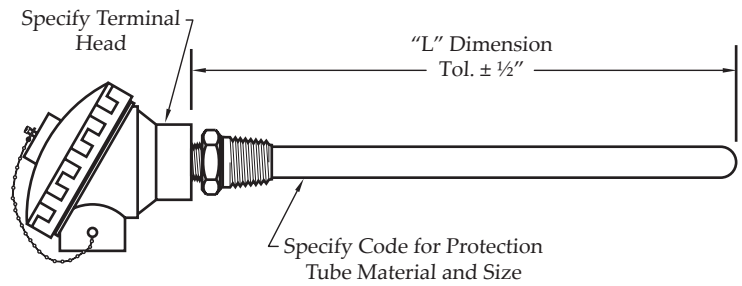

STYLE TPTC - Ceramic Protection Tube with Hex Fitting

Table 1: Thermocouple Type

Thermocouple Type Codes				Limits of Error
E	J	K	T	Standard Limits
2	3	4	8	Special Limits

Table 2: Element Type

Code	Material Type
L	Beaded, 8 Gauge, Single, Specify Junction
M	Beaded, 14 Gauge, Single, Specify Junction
N	Beaded, 14 Gauge, Dual, Specify Junction
O	MI Cable, 18 Gauge, Single, Specify Junction GND/UNG
P	MI Cable, 18 Gauge, Dual, Specify Junction GND/UNG

Table 3: Ceramic Tube Size

Code	IPS (Nominal)
F	3/8" (.375)
L	11/16" (.688)
M	3/4" (.750)
P	7/8" (.875)
S	1" (1.00)

Table 4: Ceramic Material

Code	Material
L	Alumina
W	Mullite

Table 5: Dimension

Specify in inches. See table on page 27 for codes.

Table 6: Ceramic Process Connection

Code	Description
1	1/2" NPT Nipple
2	3/4" NPT Nipple
3	1/2" NPT Hex Nipple
4	3/4" NPT Hex Nipple
5	1/2" NPT N-U-N
6	3/4" NPT N-U-N

Table 7: Extension Material

Code	Material
4	304 Stainless Steel
6	316 Stainless Steel
B	Brass
K	Black Pipe
R	Steel

Table 8: Screw Cover Terminal Heads

Code	Screw Cover Head Materials
A	1/2" NPT Conduit, Aluminum Head
B	3/4" NPT Conduit, Aluminum Head
C	1/2" NPT Conduit, Cast Iron Head
D	3/4" NPT Conduit, Cast Iron Head
M	1/4" NPT Conduit Connection, Miniature Plastic Head
P	1/2" NPT Conduit, Grey Delrin Head
W	1/2" NPT Conduit, White Polypropylene Head
Z	1/2" NPT Conduit, Explosion Proof Aluminum Head
Y	3/4" NPT Conduit, Explosion Proof Aluminum Head

Part Number Sequence

TPTC-KM-LL140-2KD

TPTC	-	K	M	-	L	L	140	-	2	K	D
TPTC		Table 1	Table 2	Table 3	Table 4	Table 5	Table 6	Table 7	Table 8		
Sensor Type & Style No.		Thermocouple Type	Element Type	Ceramic Tube Size	Ceramic Material	"L" Dim.	Ceramic Process Conn.	Extension Material	Terminal Heads		

Industrial Process Thermocouples

BASE METAL 90° PROTECTION TUBE ASSEMBLY

The TPA Style Thermocouple assembly features a base metal thermocouple element and metal protection tube with a 90° angle design for over-the-side application.

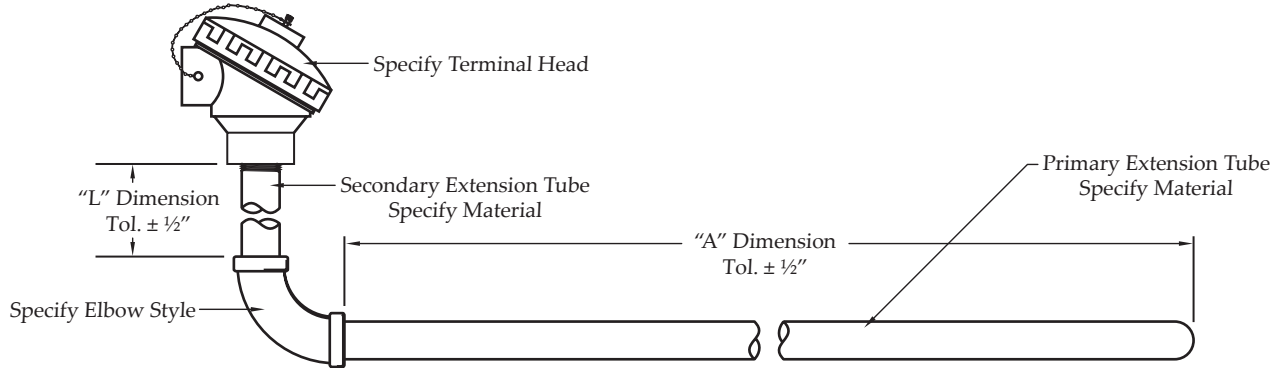

STYLE TPA - 90° Protection Tube

Table 1: Thermocouple Type

Thermocouple Type Codes				Limits of Error
E	J	K	T	Standard Limits
2	3	4	8	Special Limits

Table 3: Protection Tube Size

Code	IPS (Nominal)
L	1/2" (.840)
M	3/4" (1.050)
N	1" (1.315)
O	1 1/4" (1.660)
P	1 1/2" (1.900)

Table 4: Wall Thickness

Code	Nominal Wall
W	Schedule 40
Y	Schedule 80
Z	Schedule 160

Table 5: Protection Tube Materials

Code	Material
4	304 Stainless Steel
6	316 Stainless Steel
5	446 Stainless Steel
8	Inconel® 600
A	Inconel® 601
R	Carbon Steel

Table 6: Elbow Style

Code	Elbow Type
F	Fixed Elbow

Table 7: Element Type

Code	Material Type
L	Beaded, 8 Gauge, Single, Specify Junction
M	Beaded, 14 Gauge, Single, Specify Junction
N	Beaded, 14 Gauge, Dual, Specify Junction
O	MI Cable, 18 Gauge, Single, Specify Junction GND/UNG
P	MI Cable, 18 Gauge, Dual, Specify Junction GND/UNG

Table 8: Dimension

Specify in inches. See table on page 27 for codes.

Table 9: AD Dimension

Specify in inches. See table on page 27 for codes.

Table 9: Screw Cover Terminal Heads

Code	Screw Cover Head Materials
A	1/2" NPT Conduit, Aluminum Head
B	3/4" NPT Conduit, Aluminum Head
C	1/2" NPT Conduit, Cast Iron Head
D	3/4" NPT Conduit, Cast Iron Head
M	1/4" NPT Conduit Connection, Miniature Plastic Head
P	1/2" NPT Conduit, Grey Delrin Head
W	1/2" NPT Conduit, White Polypropylene Head
Z	1/2" NPT Conduit, Explosion Proof Aluminum Head
Y	3/4" NPT Conduit, Explosion Proof Aluminum Head

Part Number Sequence TPA-JL-LW406H-410HFB

TPA	-	J	L	-	L	W	4	06H	-	4	10H	F	B
TPA		Table 1	Table 2	Table 3	Table 4	Table 5	Table 6	Table 5	Table 7	Table 8	Table 9		

Sensor Type Thermocouple Element Tube Wall Primary Tube "L" Secondary "A" Elbow Terminal & Style No. Type Type Size Thickness Material Dim. Tube Material Dim. Style Head

Industrial Process Thermocouples

BASE METAL THERMOCOUPLE ELEMENTS

The TEBA and TEBD Style Thermocouples are base metal replacement elements for all ceramic or metal protection tube assemblies.

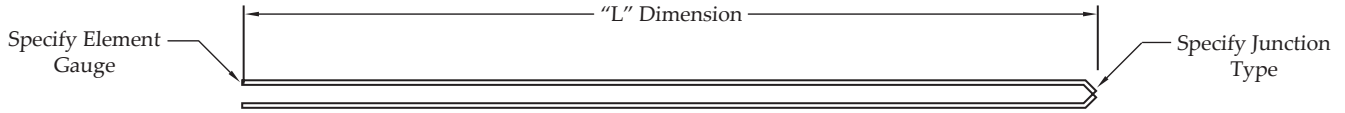

STYLE TEBA - Bare Element Thermocouple

Table 1: Thermocouple Type

Thermocouple Type Codes				Limits of Error
E	J	K	T	Standard Limits
2	3	4	8	Special Limits

Table 2: Junction Type

Code	Single Junction
B	Buttwelded
D	Twisted & Welded

Table 3: Bare Element Gauge

Code	Thermocouple Wire Gauge Size
08	8 Gauge
14	14 Gauge
20	20 Gauge
24	24 Gauge

Table 4: Termination

Code	Termination
0	2" Split Ends
1	#6 Spade Lug
3	Standard Plug
M	Mini Plug

Table 5: Dimension

Specify in inches. See table on page 27 for codes.

Part Number Sequence TEBA-JB-080022H0

TEBA	-	J	B	-	08	00	22H	0
TEBA		Table 1	Table 2		Table 3		Table 4	Table 5
Sensor Type & Style No.		Thermocouple Type	Junction Type		Bare Element Gauge		"L" Dimension	Termination

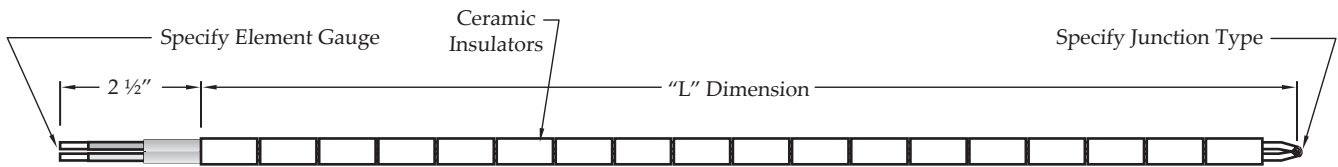

STYLE TEBD - Insulated Thermocouple

Table 1: Thermocouple Type

Thermocouple Type Codes				Limits of Error
E	J	K	T	Standard Limits
2	3	4	8	Special Limits

Table 2: Junction Type

Code	Single Junction
B	Buttwelded
D	Twisted & Welded
Code	Dual Junction
F	Buttweld, 14 GA & 20 GA only
M	Twisted & Welded, 14 GA & 20 GA only

Table 3: Element Gauge

Code	Thermocouple Wire Gauge Size
08	8 Gauge
14	14 Gauge
20	20 Gauge
24	24 Gauge

Table 4: Insulator Type

Code	Description
1	Single Round Insulator
2	1" Long Oval Insulator
3	1" Long Round Insulator
4	3" Long Round Insulator
5	3" Long Oval Insulator

Table 5: Insulator Material

Code	Description
A	Alumina
M	Mullite
C	Ceramic

Table 6: Dimension

Specify in inches. See table on page 27 for codes.

Table 7: Termination

Code	Termination
0	2" Split Ends
1	#6 Spade Lug
3	Standard Plug
M	Mini Plug

Part Number Sequence TEBD-JB-081M22H0

TEBD	-	J	B	-	08	1	M	22H	0
TEBD		Table 1	Table 2		Table 3	Table 4	Table 5	Table 6	Table 7
Sensor Type & Style No.		Thermocouple Type	Junction Type		Bare Element Gauge	Insulator Type	Insulator Material	"L" Dimension	Termination

Industrial Process Thermocouples

BASE METAL THERMOCOUPLE ELEMENTS

The TEAB Style Thermocouple is a replacement element for the TPA 90° angle protection tube thermocouple assembly.

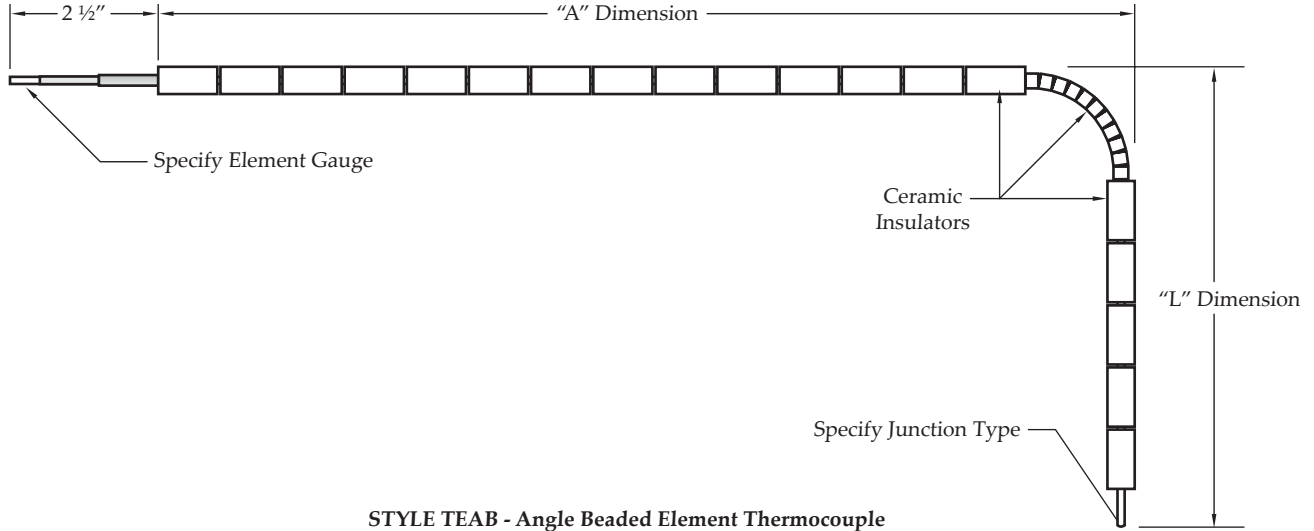

Table 1: Thermocouple Type

Thermocouple Type Codes				Limits of Error
E	J	K	T	Standard Limits
2	3	4	8	Special Limits

Table 2: Junction Type

Code	Single Junction
B	Buttwelded
D	Twisted & Welded

Table 3: Bare Element Gauge

Code	Thermocouple Wire Gauge Size
08	8 Gauge
14	14 Gauge
20	20 Gauge

Table 4: "L" Dimension

Specify in inches. See table on page 27 for codes.

Table 5: "A" Dimension

Specify in inches. See table on page 27 for codes.

Part Number Sequence

TEAB-JB-1412D-32M

TEAB	-	J	B	-	14	12D	-	32M
TEAB		Table 1	Table 2		Table 3	Table 4		Table 5
Sensor Type & Style No.		Thermocouple Type	Junction Type		Bare Element Gauge	"L" Dimension		"A" Dimension

Industrial Process Thermocouples

NOBLE METAL THERMOCOUPLE ELEMENTS

The TENE Style Thermocouple is a noble metal element designed as a replacement for high temperature protection tube assemblies.

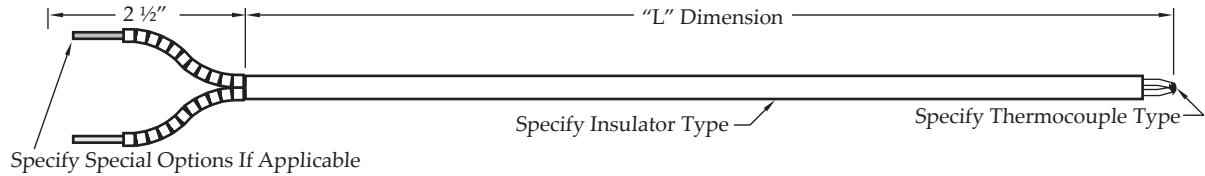

Insulated Element without Collar

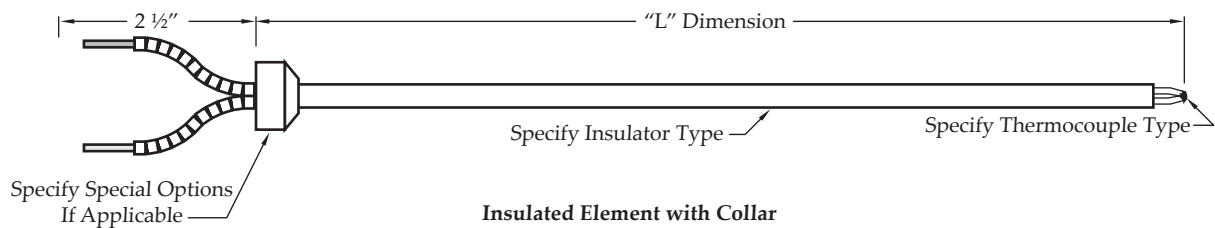

Insulated Element with Collar

STYLE TENE - Noble Metal Element Thermocouple

Table 1: Thermocouple Quantity

Code	Description
S	Single
D	Dual

Table 2: Calibration Type

Code	Size
R	R Calibration
S	S Calibration
B	B Calibration
C	C Calibration

Table 3: Insulator Size

Code	Size
B	1/8" (.125")
C	3/16" (.188")
D	1/4" (.250")

Table 4: Insulator Material

Code	Description
A	Alumina
M	Mullite

Table 5: Dimension

Specify in inches. See table on page 27 for codes.

Table 6: Element Position

Code	Description
S	Surface
R	Recessed

Table 7: Collar

Code	Description
0	No Collar
C	Collar

Table 8: Limits of Error

Code	Description
0	Standard
L	Special

Table 9: Termination

Code	Termination
0	2" Split Ends
1	#6 Spade Lug
3	Standard Plug
M	Mini Plug

Part Number Sequence

TENE-SR24-CM06H0000

TENE - S R 24 - C M 06H 0 0 0 0

TENE Table 1 Table 2 Table 3 Table 4 Table 5 Table 6 Table 8 Table 7 Table 9

Sensor Type Thermocouple Calibration Gauge Insulator Insulator "L" Element Limits Collar Termination & Style No. Quantity Type Size Material Dimension Position of Error

Industrial Process Thermocouples

NOBLE METAL THERMOCOUPLE WITH SINGLE CERAMIC TUBE

The TSPT Style Thermocouple assembly features a noble metal thermocouple and single ceramic protection tube. A variety of process connection and terminal housing options are available.

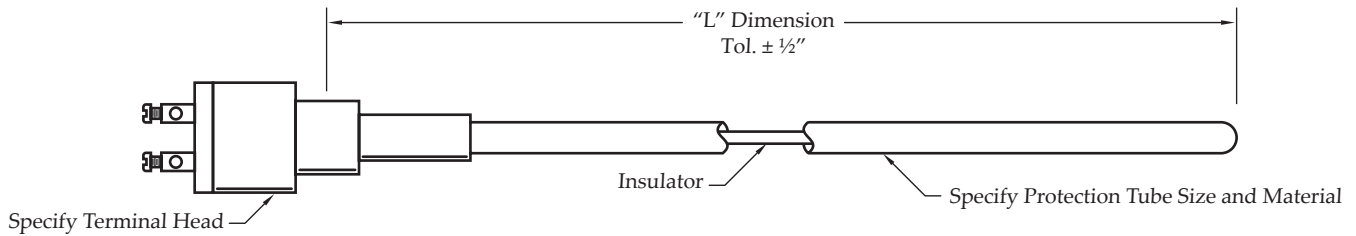

STYLE TSPT - Single Tube Assembly

Table 1: Thermocouple Type

Element Type and Gauge			
Code	T/C Quantity	Chemical Type	Gauge
SR24	Single	R	24
SS24	Single	S	24
SB24	Single	B	24
DR24	Dual	R	24
DS24	Dual	S	24
DB24	Dual	B	24

Table 2: Protection Tube

Code	Size / Material
A	3/8 OD Mullite
B	3/8 OD Alumina
C	11/16 OD Mullite
D	11/16 OD Alumina
X	Special

Table 3: Dimension

Specify in inches. See table on page 27 for codes.

Table 4: Process Connection

Code	Description
0	No Process Fitting
G	1/2" NPT, Brass Bushing
H	1/2" NPT, Stainless Steel Bushing
J	3/4" NPT, Brass Bushing
K	3/4" NPT, Stainless Steel Bushing

Table 5: Termination Options

Code	Termination Type
K	Open Head Brass Terminal
B	3/4" NPT Conduit, Aluminum Head
C	1/2" NPT Conduit, Cast Iron Head

Part Number Sequence

TSPT-SR24-C06H-KB

TSPT	-	SR24	-	C	06H	-	K	B
TSPT		Table 1		Table 2	Table 3		Table 4	Table 5
Sensor Type & Style No.		Thermocouple Type		Protection Tube	"L" Dimension		Process Connection	Termination Options

Industrial Process Thermocouples

NOBLE METAL THERMOCOUPLE WITH DOUBLE CERAMIC TUBE

The TDPT Style Thermocouple assembly features a noble metal thermocouple element with a primary and secondary ceramic protection tube for additional protection in extreme environments.

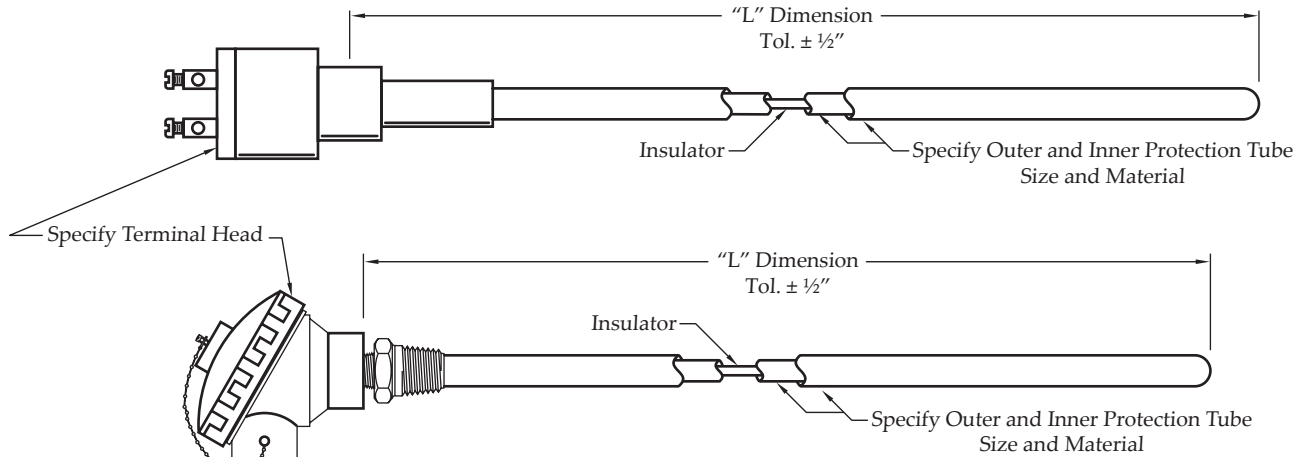

STYLE TDPT - Double Tube Assembly

Table 1: Thermocouple Type

Element Type and Gauge			
Code	T/C Quantity	Chemical Type	Gauge
SR24	Single	R	24
SS24	Single	S	24
SB24	Single	B	24
DR24	Dual	R	24
DS24	Dual	S	24
DB24	Dual	B	24

Table 2: Outer Protection Tube

Code	Size/ Material
LL	1 1/16" OD Alumina
LW	1 1/16" OD Mullite
PZ	7/8" OD LT-1
UA	1.05" OD Inconel® 601

Table 3: Dimension
Specify in inches.
See table on page 27 for codes.

Table 4: Inner Protection Tube

Code	Size
F	3/8" Diameter

Table 5: Process Connection

Code	Description
0	No Process Fitting
G	1/2" NPT, Brass Bushing
H	1/2" NPT, Stainless Steel Bushing
J	3/4" NPT, Brass Bushing
K	3/4" NPT, Stainless Steel Bushing

Table 6: Termination Options

Code	Termination Type
K	Open Head Brass Terminal
B	3/4" NPT Conduit, Aluminum Head
D	3/4" NPT Conduit, Cast Iron Head

Part Number Sequence

TDPT-SR24-LL06HF-KB

TDPT	-	SR24	-	LL	06H	F	-	K	B
TDPT		Table 1		Table 2	Table 3	Table 4		Table 5	Table 6
Sensor Type & Style No.		Thermocouple Type		Outer Protection Tube	"L" Dimension	Inner Protection Tube		Process Connection	Termination Options

Industrial Process Thermocouples

REPLACEMENT CERAMIC PROTECTION TUBES

Replacement ceramic protection tubes are available for all thermocouple protection tube assemblies.

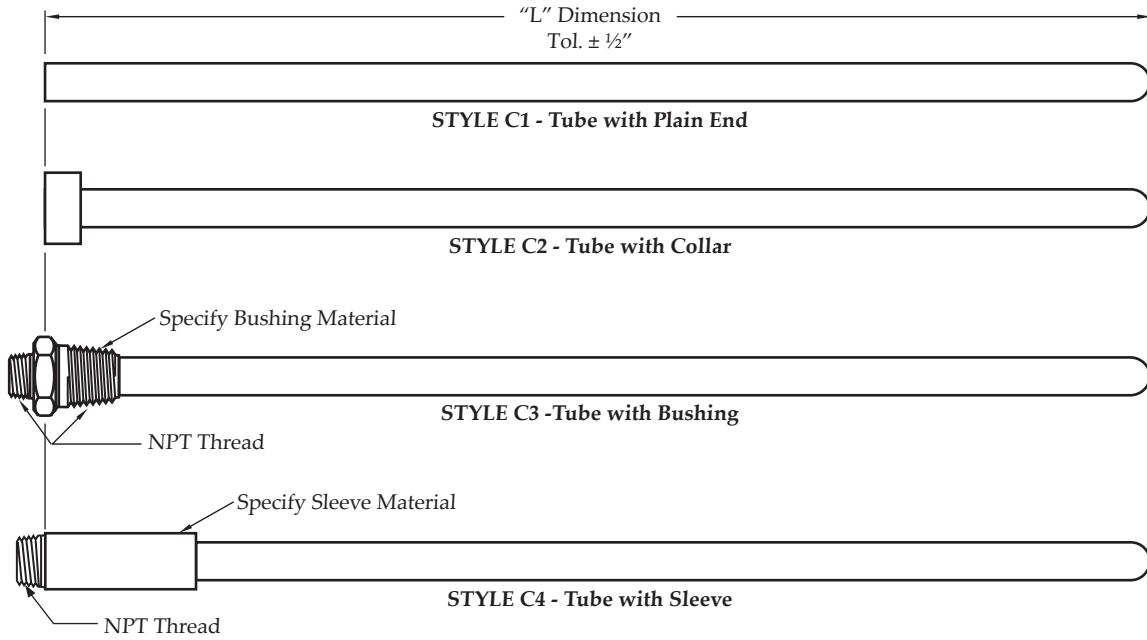

Table 3: Tube Material

Code	Material
W	Mullite
L	Alumina

Table 4: Tube Size

Code	Description
D	3/16" ID x 1/4" OD
F	1/4" ID x 3/8" OD
H	3/8" ID x 1/2" OD
L	7/16" ID x 11/16" OD
S	3/4" ID x 1" OD
Q	1" ID x 1 1/4" OD

Table 4: Fitting Options

Code	Description
0	No Fitting Option
1	1/2" x 1/2" NPT Hex Nipple
2	3/4" x 1/2" NPT Hex Nipple
3	3/4" x 3/4" NPT Hex Nipple
4	1" x 3/4" NPT Hex Nipple
5	1" x 1" NPT Hex Nipple
6	1 1/4" x 1" NPT Hex Nipple
7	7/8" - 27 Sleeve
8	1/2" Schedule 40 Pipe
9	1/2" NPT Schedule 40 Pipe
A	3/4" Schedule 40 Pipe
B	3/4" NPT Schedule 40 Pipe
C	1" Schedule 40 Pipe
D	1" NPT Schedule 40 Pipe
E	3/4" x 1/2" NPT Hex Bushing
F	1" x 3/4" NPT Hex Bushing
G	1 1/4" x 1" NPT Hex Bushing

Table 5: Dimension

Specify in inches. See table on page 27 for codes.

Table 5: Fitting Material

Code	Material
0	No Fitting
4	304 Stainless Steel
6	316 Stainless Steel
B	Brass
K	Black Pipe
R	Carbon Steel

Part Number Sequence

C1-WF06H-B4

C3	-	W	F	06H	-	B	4
C3		Table 1	Table 2	Table 3		Table 4	Table 5
Sensor Type & Style No.		Tube Material	Tube Size	"L" Dimension		Fitting Options	Fitting Material

Industrial Process Thermocouples

REPLACEMENT METAL PROTECTION TUBES

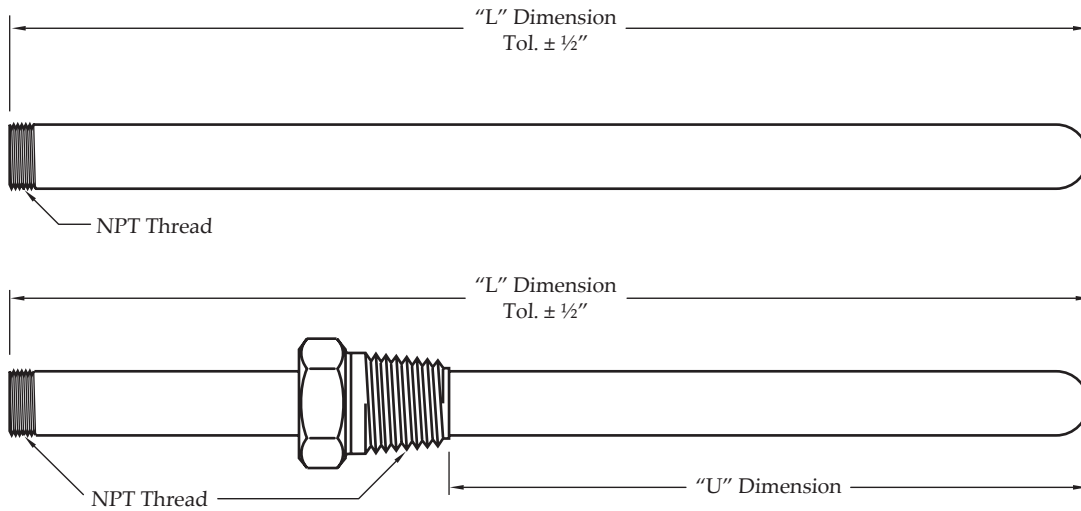

STYLE RP2 - Tube With Fixed Bushing

Table 1: Protection Tube Size

Code	ISP (Nominal)
L	1/2" (.840)
M	3/4" (1.050)
N	1" (1.315)
O	1 1/4" (1.660)
P	1 1/2" (1.900)

Table 2: Wall Thickness

Code	Nominal Wall
W	Schedule 40
Y	Schedule 80
Z	Schedule 160

Table 3: Tube Materials

Code	Material
1	310 Stainless Steel
4	304 Stainless Steel
5	446 Stainless Steel
6	316 Stainless Steel
8	Inconel® 600

Table 5: Fitting Options

Code	Description
0	No Fitting Option
1	1/2" x 1/2" NPT Hex Nipple
2	3/4" x 1/2" NPT Hex Nipple
3	3/4" x 3/4" NPT Hex Nipple
4	1" x 3/4" NPT Hex Nipple
5	1" x 1" NPT Hex Nipple
6	1" x 1 1/4" NPT Hex Nipple
B	1/8" NPT Bushing
C	1/4" NPT Bushing
D	3/8" NPT Bushing
E	1/2" NPT Bushing
F	3/4" NPT Bushing
G	1" NPT Bushing

Table 6: Fitting Material

Code	Material
0	No Fitting
4	304 Stainless Steel
6	316 Stainless Steel
B	Brass
D	Copper
K	Black Pipe
R	Steel

Table L Dimension

Specify in inches. See table on page 27 for codes.

Table U Dimension

Specify in inches. See table on page 27 for codes.

Part Number Sequence RP2-LW406H-B4000

RP2	-	L	W	4	06H	-	B	4	000
RP2		Table 1	Table 2	Table 3	Table 4		Table 5	Table 6	Table 7
Sensor Type & Style No.		Tube Size	Wall Thickness	Tube Material	"L" Dimension		Fitting Options	Fitting Material	"U" Dimension

Industrial Process Thermocouples

SILICON CARBIDE PROTECTION TUBE ASSEMBLY

The PSC1 and PSC2 Style Thermocouple assemblies feature a silicon carbide protection tube along with an inner ceramic tube for additional protection of the element.

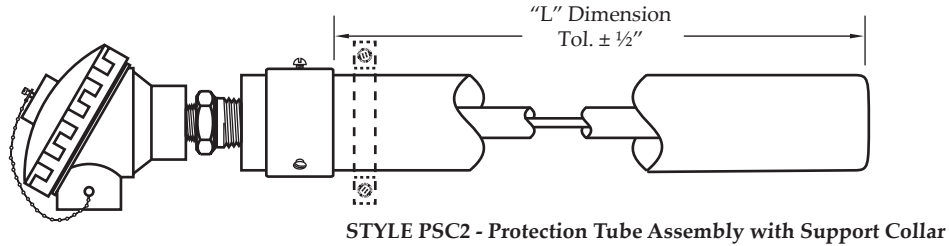
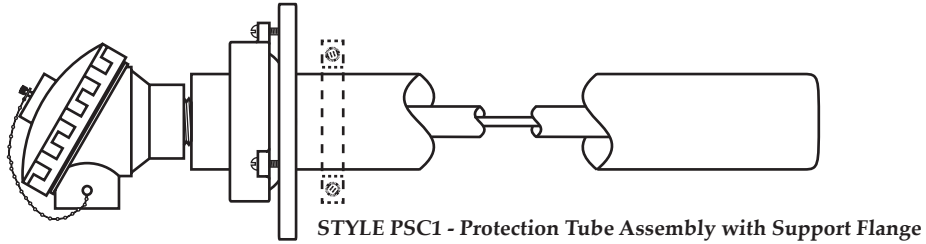

Table 1: Thermocouple Type

Element Type and Gauge	
Single	Dual
SR24	DR24
SS24	DS24
SB24	DB24

Table 2: Dimension

Specify in inches. See table on page 27 for codes.

Table 3: Terminal Heads

Code	Description
A	1/2" NPT Conduit, Aluminum Head
B	3/4" NPT Conduit, Aluminum Head
C	1/2" NPT Conduit, Cast Iron Head
D	3/4" NPT Conduit, Cast Iron Head
P	Specify Conduit, Grey Delrin Head
W	Specify Conduit, White Polypropylene Head
Z	Specify Conduit, Explosion Proof Aluminum Head

Table 4: Flange Option

Code	Description
0	No Flange
F	Split Flange

Part Number Sequence PSC1-SR24-600-AF

PSC1	-	SR24	-	600	-	A	F
PSC1		Table 1		Table 2		Table 3	Table 4
Sensor Type & Style No.		Thermocouple Type		"L" Dimension		Terminal Head	Flange Option



closing the loop on thermal solutions

Industrial Process Thermocouples

THERMOCOUPLE TECHNICAL DATA - WIRE CODE STANDARDS

Color-codes have been adopted by various national and international standard agencies for identification of thermocouple wire and thermocouple products. In the United States, thermocouple grade wire normally has a brown overall jacket. For Types B, R, and S the color-codes relate to the compensating cable normally used.

Type	United States ANSI	United Kingdom BS	Germany DIN	France NFC	Japan JIS C1610-1981
E	Purple + Purple - Red	Brown + Brown - Blue	Black + Red - Black		Purple + Red - White
J	Black + White - Red	Black + Yellow - Blue	Blue + Red - Blue	Black + Yellow - Black	Yellow + Red - White
K	Yellow + Yellow - Red	Red + Brown - Blue	Green + Red - Green	Yellow + Yellow - Purple	Blue + Red - White
N	Orange + Orange - Red				
B	Grey + Grey - Red		Grey + Red - Grey		Grey + Red - White
R	Green + Black - Red	Green + White - Blue			Black + Red - White
S	Green + Black - Red	Green + White - Blue	White + Red - White	Green + Yellow - Green	Black + Red - White
T	Blue + Blue - Red	Blue + White - Blue	Brown + Red - Brown	Blue + Yellow - Blue	Brown + Red - White



closing the loop on thermal solutions

Industrial Process Thermocouples

THERMOCOUPLE TECHNICAL DATA

MATERIAL SELECTION GUIDE FOR THERMOWELL APPLICATIONS

Chemical	Temp° F	Concentration %	Recommended Material	Chemical	Temp° F	Concentration %	Recommended Material
Acetic Acid	212	All	Monel, 430 SS	Chloroacetic Acid	212	All	Hastelloy - C
Acetic Anhydride	300	-	Nickel, Monel	Chloroform, Dry	212	-	Monel
Acetone	212	All	304 SS	Chromic Acid	212	50	Hastelloy - C, 316 SS
Acetylene	400	All	304 SS, Monel, Nickel	Cider	212	All	304 SS
Alcohols (Methyl, Ethyl)	212	All	304 SS	Citric Acid	212	All	Hastelloy - C, 316 SS
Aluminum (Potassium or Sodium)	300	All	Hastelloy - C	Coal Tar	212	-	304 SS
Aluminum Acetate	-	Sat.	304 SS	Copper (10) Chloride	212	All	Hastelloy - C
Aluminum Chloride	212	All	Hastelloy - B	Copper (10) Nitrate	300	All	316 SS
Aluminum Sulfate	212	All	316 SS	Copper (10) Sulfate	300	All	316 SS
Ammonia, Dry	212	All	304 SS, 316 SS	Copper Plating Solution (Cyanide)	180	-	304 SS
Ammonium Hydroxide (Ammonia, Aqua)	212	All	304 SS, 316 SS	Copper Plating Solution (Acid)	75	-	304 SS
Ammonium Chloride	300	50	Monel	Corn Oil	300	-	304 SS
Ammonium Nitrate	300	All	304 SS	Cottonseed Oil	300	-	304 SS
Ammonium Sulfate	212	All	316 SS	Creosote, Crude	200	All	304 SS, Monel
Amyl Acetate	300	All	304 SS, Monel	Crude Oil	300	-	Monel
Aniline	75	All	Monel	Ethyl Acetate	300	All	Monel
Asphalt	250	All	304 SS	Ethyl Chloride, Dry	500	-	Steel
Barium Compound	70	All	Hastelloy - C	Ethylene Glycol	212	All	Steel
Beer	70	-	304 SS	Ethylene Oxide	75	-	Steel
Benzene (Benzol)	212	-	Steel (C1018)	Fatty Acids	500	All	316 SS
Benzine	-	-	Steel (C1018)	Ferric Chloride	75	All	Hastelloy - C, Tantalum
Benoic Acid	212	All	316 SS	Ferric Sulfate	70	All	304 SS
Bleaching Powder	70	20	Monel	Formaldehyde	212	All	316 SS
Borax	212	All	Brass	Formic Acid	150	All	316 SS
Bordeaux Mixture	200	-	304 SS	Freon	-	-	Steel
Boric Acid	212	All	316 SS	Fluorine, Anhydrous	100	-	304 SS
Bromine	125	Dry	Monel, Tantalum	Furfural	450	-	316 SS
Butabien	-	All	Brass, 304 SS	Gallic Acid	150	5	Monel
Butane	70	All	Steel, 304 SS	Gasoline	70	-	Steel, 304 SS
Butyl Alcohol	212	All	304 SS	Glucose	300	All	304 SS
Butyric Acid	70	5	Hastelloy - C, 304 SS	Glue pH 6-8	300	All	304 SS
Calcium Bisulphite	75	All	Hastelloy - C, 316 SS	Glycerin	212	All	Brass, 304 SS
Calcium Chloride	212	All	Hastelloy - C, 304 SS	Glycerol	-	-	Brass, 304 SS
Calcium Hydroxide	212	50	Hastelloy - C, 317 SS	Hydrobromic Acid	212	All	Hastelloy - B
Calcium Hypochlorite	70	20	Monel	Hydrochloric Acid (37-38%)	225	All	Hastelloy - B
Carbolic Acid	212	All	316 SS	Hydrogen Chloride, Dry	300	-	304 SS
Carbon Dioxide, Dry	212	All	Brass, Steel (C1018)	Hydrocyanic Acid	212	All	316 SS
Carbonated Water	212	All	304 SS	Hydrofluoric Acid	212	60	Monel, Hastelloy - C
Carbonated Beverages	212	All	304 SS	Hydrogen Fluoride, Dry	175	-	Steel
Carbon Disulfide	200	-	304 SS	Hydrofluogilicic Acid	212	40	Monel
Carbon Tetrachloride	70	All	Monel	Hydrogen Peroxide	212	10-100	316 SS
Chlorine, Dry	-	100	Monel	Iodine	70	All	Tantalum
Chlorine, Moist	212	All	Hastelloy - C	Kerosene	70	-	Steel, 304 SS



closing the loop on thermal solutions

Industrial Process Thermocouples

THERMOCOUPLE TECHNICAL DATA MATERIAL SELECTION GUIDE FOR THERMOWELL APPLICATIONS

Chemical	Temp° F	Concentration %	Recommended Material
Lacquers & Thinners	300	All	Monel
Lactic Acid	212	All	316 SS, Tantalum
Lime	212	All	316 SS
Linseed Oil	75	-	Steel, 304 SS
Magnesium Chloride	212	50	Nickel
Magnesium Hydroxide	75	All	304 SS
Magnesium Sulfate	212	50	Nickel
Malic Acid	212	All	316 SS
Mercuric Chloride	212	50	Nickel
Mercury	-	-	Steel, 304 SS
Methane	70	All	Steel
Methylene Chloride	212	All	304 SS
Methyl Chloride, Dry	75	-	Steel
Milk, Fresh or Sour	180	-	304 SS, Nickel
Molasses	300	All	304 SS
Natural Gas	70	-	304 SS
Nitric Acid	75	All	304 SS
Nitric Acid	300	All	316 SS, Tantalum
Nitrobenzene	70	-	304 SS
Oxygen	70	All	Steel
Oleic Acid	500	All	316 SS
Oxalic Acid	212	All	Monel
Palmitic Acid	500	All	316 SS
Photographic Bleaching	100	All	304 SS
Phosphoric Acid	212	All	316 SS
Phenol	-	All	316 SS
Potassium Compounds	See Sodium Compounds		
Propane	70	All	Steel
Rosin	700	100	316 SS
Sea Water	212	-	Monel
Soap & Detergents	212	All	304 SS
Sodium Bicarbonate	212	20	316 SS
Sodium Bisulphite	212	20	304 SS
Sodium Bisulfate	212	20	304 SS
Sodium Carbonate	212	40	316 SS
Sodium Chloride	300	30	Monel
Sodium Chromate	212	All	316 SS
Sodium Cyanide	212	All	304 SS
Sodium Hydroxide	212	30	316 SS
Sodium Hypochlorite	75	10	Hastelloy - C
Sodium Nitrate	212	40	304 SS
Sodium Nitrate	75	20	316 SS
Sodium Phosphate	212	10	Steel
Sodium Silicate	212	10	Steel
Sodium Sulfate	212	30	316 SS
Sodium Sulfide	212	10	316 SS
Sodium Sulfite	212	30	304 SS

Chemical	Temp° F	Concentration %	Recommended Material
Sodium Thiosulfate	212	All	304 SS
Steam	-	-	304 SS
Stearic Acid	500	All	316 SS
Sugar Solutions	300	All	304 SS
Sulfur	500	-	304 SS
Sulfur Chloride, Dry	75	-	316 SS
Sulfur Dioxide, Dry	500	-	316 SS
Sulfur Trioxide, Dye	500	-	316 SS
Sulfuric Acid	212	5	Hastelloy - B
Sulfuric Acid	212	5-100	Hastelloy - B, Hastelloy - D
Sulfuric Acid, Fuming	175	-	Hastelloy - C
Sulfurous Acid	75	20	316 SS
Titanium Tetrachloride	75	All	316 SS
Tannic Acid	75	40	Hastelloy - B
Toluene	75	-	Steel
Trichloroacetic Acid	75	All	Hastelloy - B
Trichlorethylene	-	-	Steel (C1018)
Turpentine	75	All	316 SS
Varnish	150	-	Steel, 304 SS
Vinegar	212	All	Monel, 304 SS
Zinc Chloride	212	All	Hastelloy - B
Zinc Sulfate	212	All	316 SS



closing the loop on thermal solutions

Plastics Industry Sensors

INTRODUCTION

Durex offers a complete line of thermocouples that are specifically designed for the plastics processing industry. These thermocouples are typically ANSI type J or K calibration and consist of a flexible thermocouple conductor insulated with fiberglass. Designs utilize factory standard bayonet fittings or threaded fittings that retrofit most plastic processing equipment that is currently on the market. Durex also offers European and Japanese retrofit parts with equivalent color codes for direct replacement in these machines.

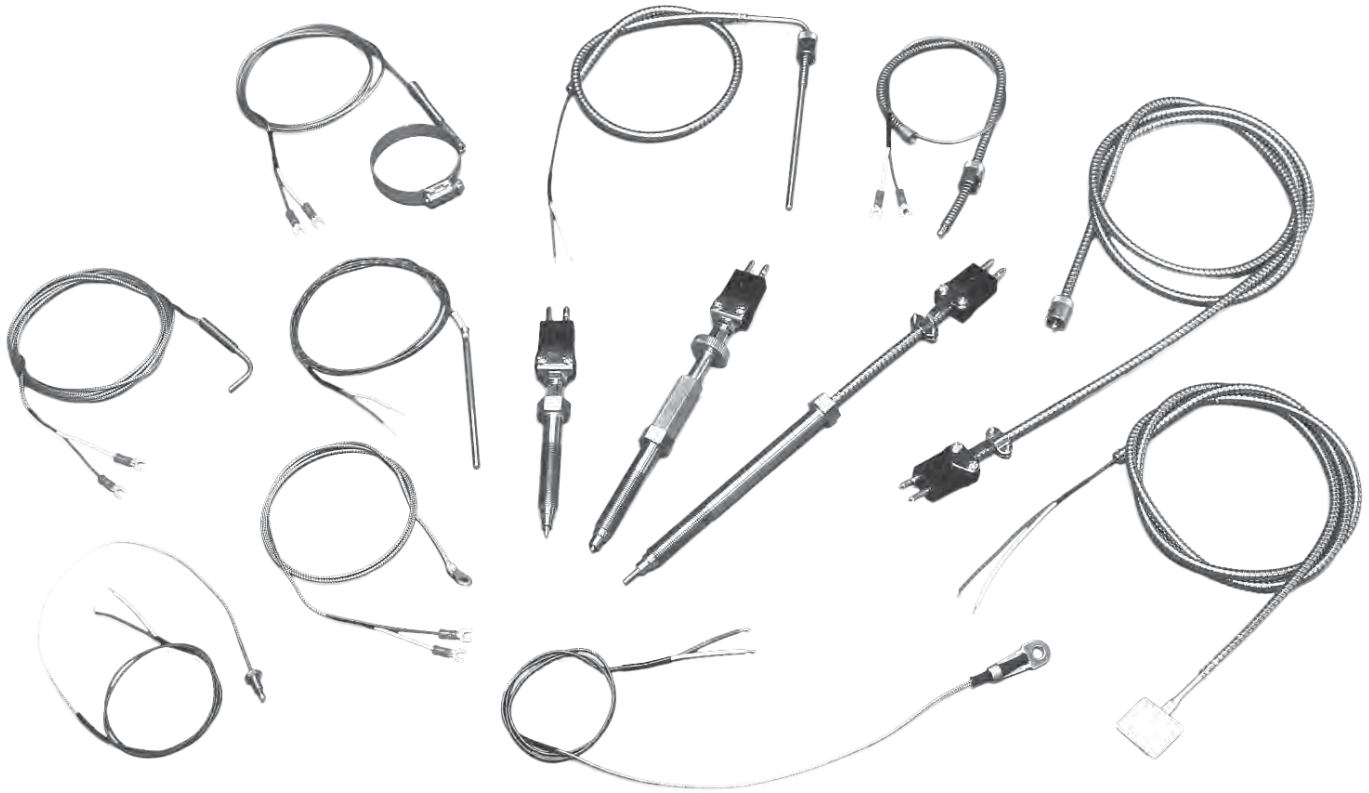

Design Features:

- Typical terminations: split leads, spade lugs, or polarized male plugs
- Adjustable to various immersion depths
- Provide fast response times
- Wide variety of sizes and styles
- Custom designs available
- Dependable temperature measurement
- Economical general purpose thermocouples

Typical Applications:

- Extrusion
- Injection Molding
- Blow Molding
- Hot Runner Systems
- Thermoforming
- Custom Die Applications

CODE DEFINITIONS AND TERMINATION TYPES

Thermocouple Type

Thermocouple Type Codes				Limits of Error
E	J	K	T	Standard Limits
2	3	4	8	Special Limits

Sheath Diameter

Code	Diameters
B	.125" or 1/8" O.D.
V	.156" or 5/32" O.D.
C	.188" or 3/16" O.D.
D	.250" or 1/4" O.D.
F	.375" or 3/8" O.D.

Junction Type

Code	Single Junction
G	Grounded
U	Ungrounded

Code Definitions

L Dimensions				B Dimensions				A Dimensions		Fractional Dimension Letter Code			
"L" dimensions are specified in whole inches and a single alpha character which represents a fraction. Enter the three digit code as follows: 3" 030 10 5/8" 10K				"B" dimensions are specified in fractions from 1/8" to 1". Use the single alpha character to indicate the tip length. Enter the code as follows: 1/8" B 5/8" K 1/4" D 3/4" M 3/8" F 7/8" P 1/2" H 1" S				"A" dimensions are specified in whole inches only. Enter the three digit code as follows: 9" 009 12" 012 36" 036 144" 144		1/16"	A	11/16"	L
										1/8"	B	3/4"	M
3/16"	C	13/16"	N	5/16"	E	15/16"	R	7/16"	G	0	No		
1/4"	D	7/8"	P	3/8"	F	1"	S	1/2"	H	Fraction			
5/8"	09K	22 1/8"	22B	9/16"	J			5/8"	K				

Termination Type Numbers

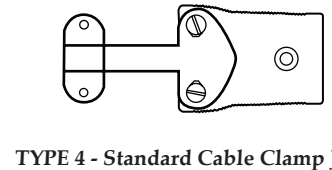
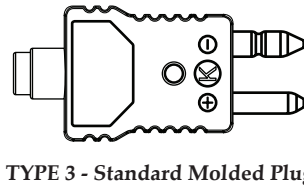
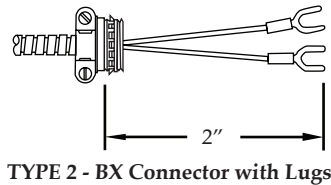
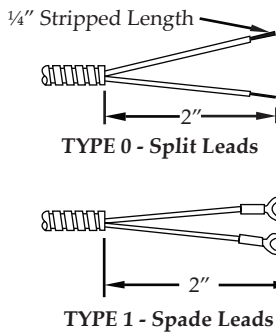

ADJUSTABLE DEPTH THERMOCOUPLE WITH SPRING

The TBA10 thermocouple uses a compression spring and bayonet lockcap which allows this design to adjust to hole depths up to 12" deep. This design also features a stainless steel tip with a silver solder junction for fast response. A tig welded junction is available upon request.

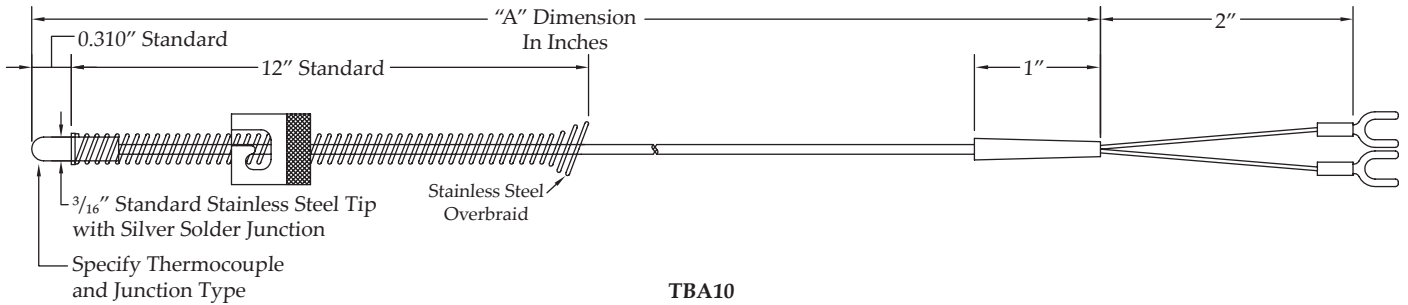

ADJUSTABLE DEPTH THERMOCOUPLE WITH ARMOR

The TBA20 thermocouple uses flexible stainless steel armor cable with a rotating bayonet lockcap on the outside diameter that adjusts to various immersion depths. The armor cable assures maximum protection of the thermocouple element for extension from the process.

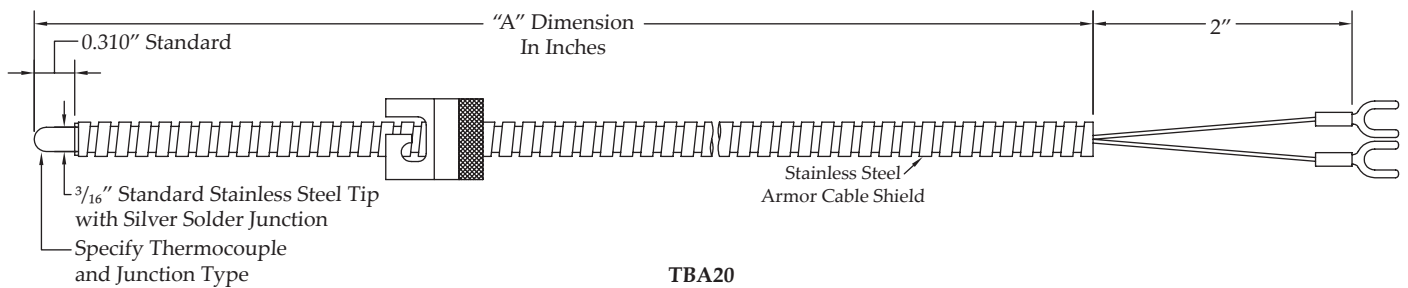

Part Number Sequence					TBA10-JG-0360	See tables on page 54
TBA10	-	J	G	-	036	0
Sensor Type & Style No.		Thermocouple Type	Junction Type		"A" Dimension	Termination Number

MELT BOLT THERMOCOUPLE

Durex melt bolts are designed for dependable temperature measurement of the plastic melt stream within extruders and injection molding equipment. Standard assemblies are supplied with mineral insulated sensing elements for extended pressure and temperature performance. Optional thermal barriers of Teflon® (500°F) and Mycalex® (900°F) are available upon request.

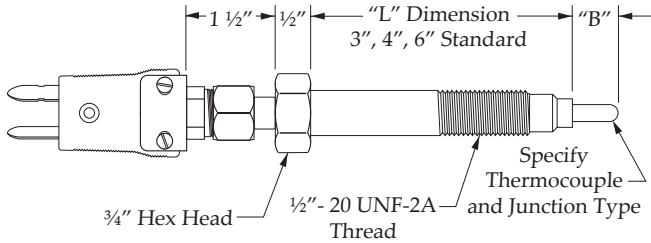

TPM0 - Melt Bolt with Standard Plug

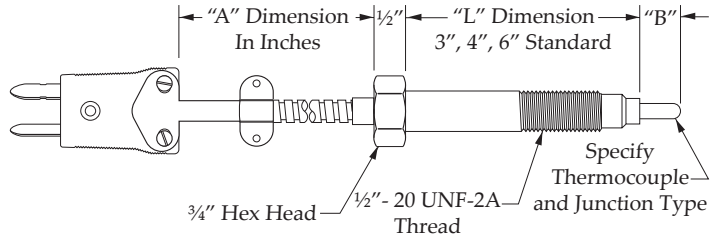

TPM1 - Melt Bolt with Standard Plug on Stainless Steel Armor

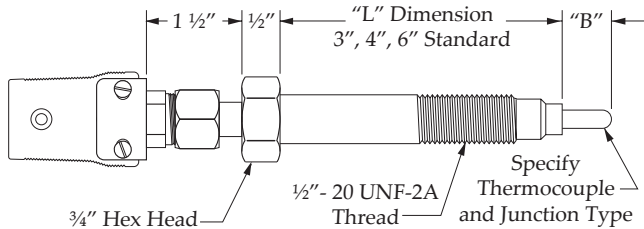

TPM2 - Melt Bolt with Standard Jack

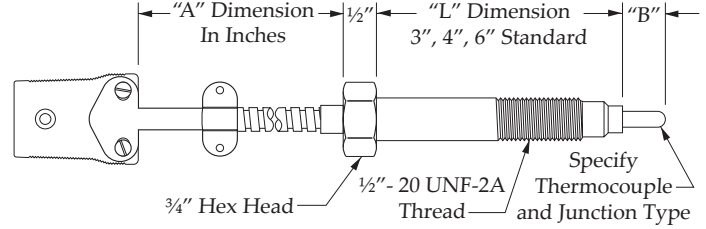

TPM3 - Melt Bolt with Standard Jack on Stainless Steel Armor

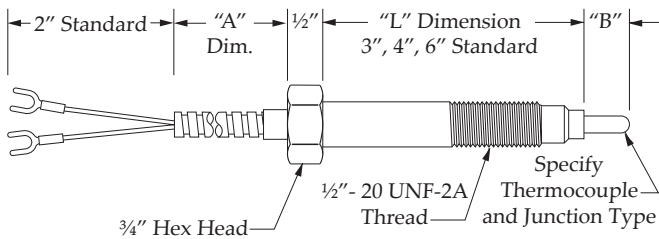

TPM4 - #6 Spade Lugs with Stainless Steel Armor

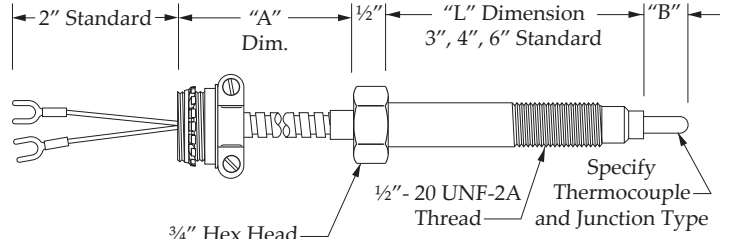

TPM5 - #6 Spade Lugs with BX Connector on Stainless Steel Armor

Part Number Sequence

TPM4-JG-030-P012

See tables on page 54

TPM4	-	J	G	-	030	-	P = 7/8"	012
Sensor Type & Style No.		Thermocouple Type	Junction Type		"L" Dimension		"B" Dimension	"A" Dimension

BLANK BOLTS

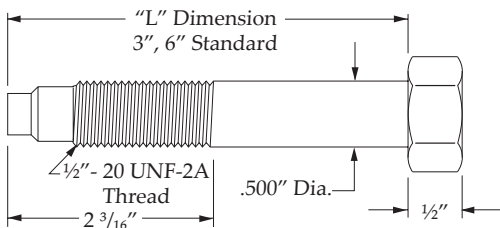

Part Number	Length Dimension
244008	3"
244009	6"

Blank bolt occupies hole when melt bolt is removed.

FIXED BAYONET THERMOCOUPLES

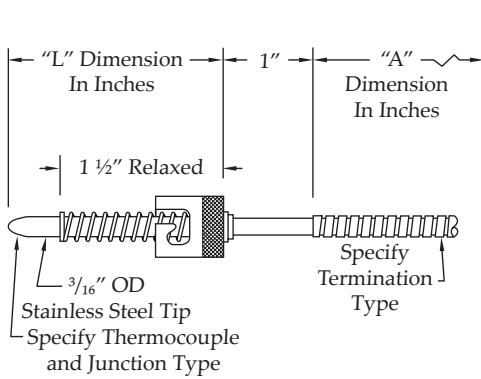

TBF00 - Straight Run Thermocouple

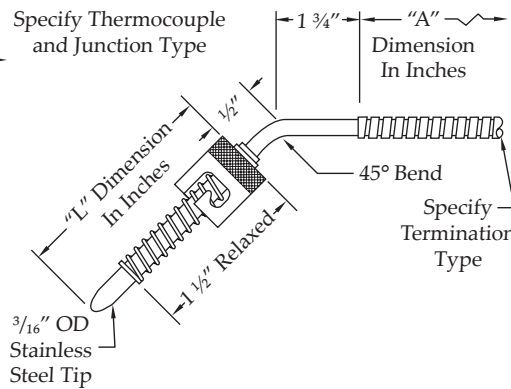

TBF45 - 45° Bend Thermocouple

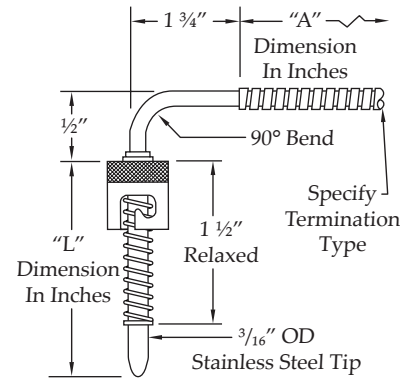

TBF90 - 90° Bend Thermocouple

Part Number Sequence

TBF45-JG-060-0241 See tables on page 54

TBF45	-	J	G	-	060	-	024	1
Sensor Type & Style No.		Thermocouple Type	Junction Type		"L" Dimension		"A" Dimension	Termination Type

COMPRESSION FITTING THERMOCOUPLE

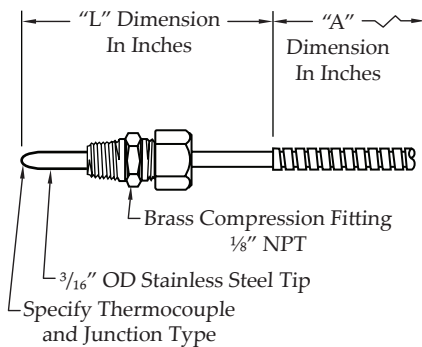

TCF00 - Straight Run Thermocouple

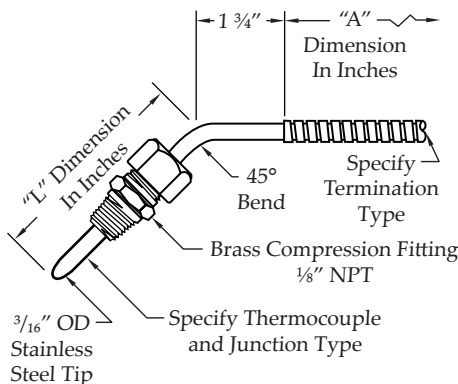

TCF45 - 45° Bend Thermocouple

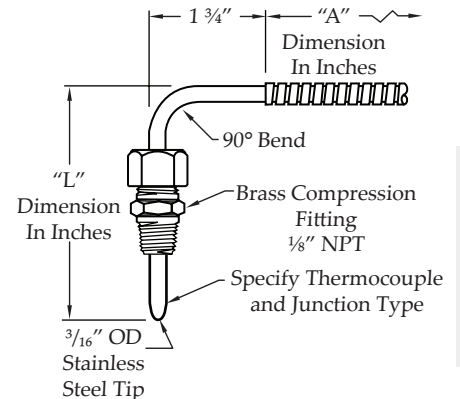

TCF90 - 90° Bend Thermocouple

Part Number Sequence

TCF00-JG-030-0361 See tables on page 54

TCF00	-	J	G	-	030	-	036	1
Sensor Type & Style No.		Thermocouple Type	Junction Type		"L" Dimension		"A" Dimension	Termination Type

ADJUSTABLE MELT BOLT THERMOCOUPLES

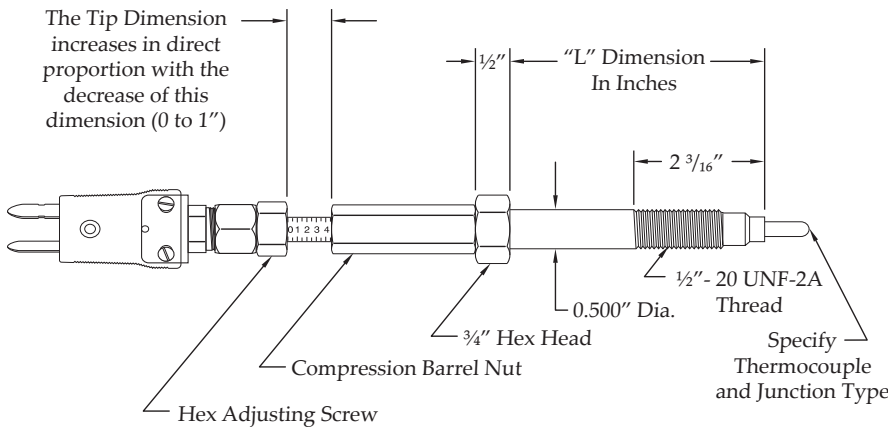

TAM1 - Adjustable Tip Melt Bolt

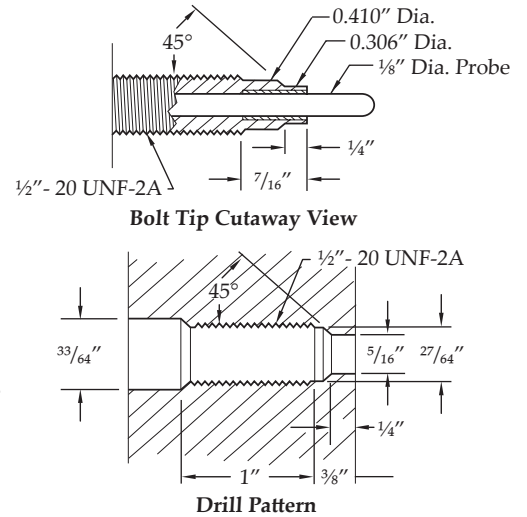

The standard assembly consists of an 1/8" Outer Diameter MgO insulated type "J" thermocouple in a stainless steel sheath. The body is stainless steel with a 1/2" - 20 UNF-2A thread. A thermal barrier reduces heat transfer from body to thermocouple. Other parts include a packing seal, compression barrel nut, hex adjusting screw, and a polarized quick-disconnect male plug. Standard immersion is adjustable from flush to 1". Standard body lengths are 3", 4", and 6" measured from the beginning of wrench flats to the bolt tip. The adjustable plastic melt thermocouple has a movable probe activated by an inner screw mechanism. The probe can be immersed into or withdrawn from the plastic melt stream while the extruder eliminates thermocouple breakage at start-up and prevents hang-up. The thermocouple is self-cleaning; as it is retracted into the body any film formed on it is scraped off.

Part Number Sequence		TAM1-JG-040	See tables on page 54
TAM1	-	J	G - 040
Sensor Type & Style No.		Thermocouple Type	Junction Type
			"L" Dimension (3, 4, 6" are Standard)

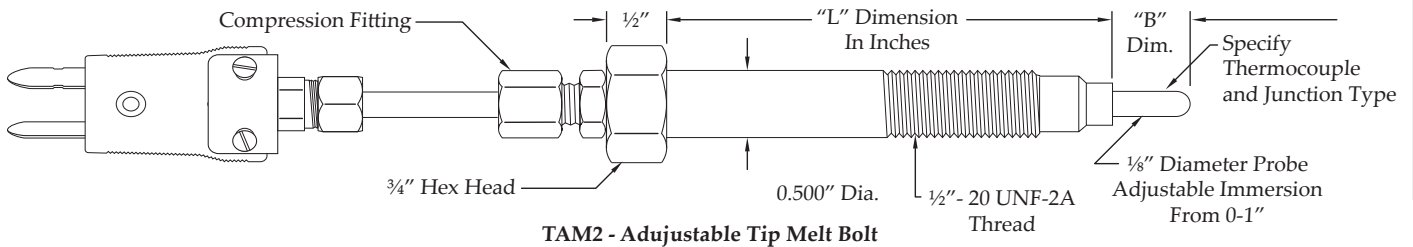

TAM2 - Adjustable Tip Melt Bolt

The TAM2 adjustable melt thermocouple features an all stainless steel construction and uses a compression fitting as the mechanism for the adjustment. The TAM2 allows for easy and economical replacement of the mineral insulated thermocouple element.

Part Number Sequence		TAM2-JG-040 - M	See tables on page 54
TAM2	-	J	G - 040 - M = 3/4"
Sensor Type & Style No.		Thermocouple Type	Junction Type
			"L" Dimension (3, 4, 6" are Standard)
			"B" Dimension

Sensors

SURFACE MOUNT THERMOCOUPLES

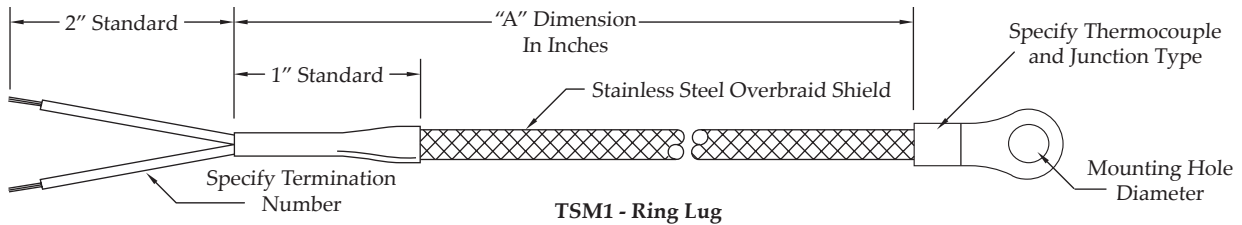

TSM1 - Ring Lug

Leadwire Conductor is Stranded with Fiberglass Insulation and Stainless Steel Overbraid Shield

Termination Options

Termination Number	Description
0	2" Split Leads
1	#6 Spade Lugs
3	Standard Plug
4	Standard Jack
X	Special, Specify

Mounting Hole Options

Mounting Hole Type	Stud Size	Hole Diameter
A	No. 6	.144"
B	No. 8	.169"
C	No. 10	.196"
D	1/4"	.266"
E	3/8"	.390"

Part Number Sequence

TSM1-JG-0240C

See tables on page 54

TSM1	-	J	G	-	024	0	C
Sensor Type & Style No.		Thermocouple Type	Junction Type		"A" Dimension	Termination Option	Mounting Hole Diameter

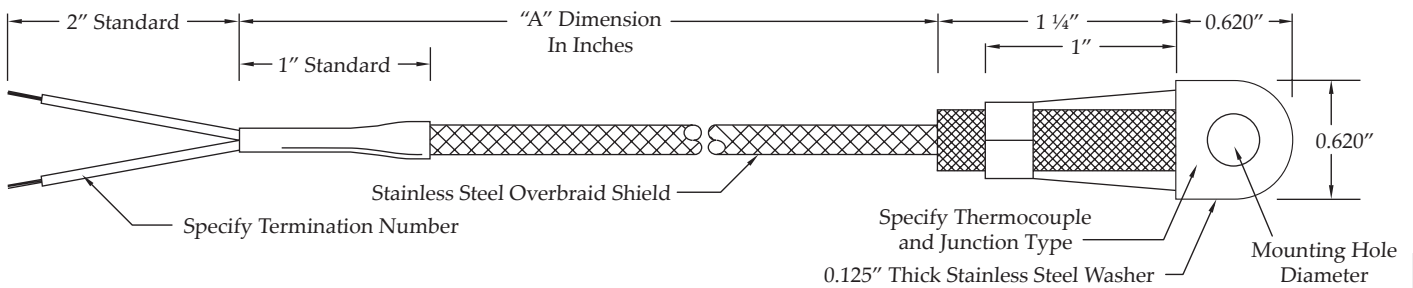

TSM2 - Gasket with Bracket

Leadwire Conductor is Stranded with Fiberglass Insulation and Stainless Steel Overbraid Shield

Termination Options

Termination Number	Description
0	2" Split Leads
1	#6 Spade Lugs
3	Standard Plug
4	Standard Jack
X	Special, Specify

Mounting Hole Options

Mounting Hole Type	Stud Size	Hole Diameter
A	1/4"	9/32"
B	5/16"	11/32"
C	3/8"	13/32"
D	7/16"	15/32"
E	1/2"	17/32"

Part Number Sequence

TSM2-JG-0180B

See tables on page 54

TSM2	-	J	G	-	018	0	B
Sensor Type & Style No.		Thermocouple Type	Junction Type		"A" Dimension	Termination Option	Mounting Hole Diameter

SURFACE MOUNT THERMOCOUPLES

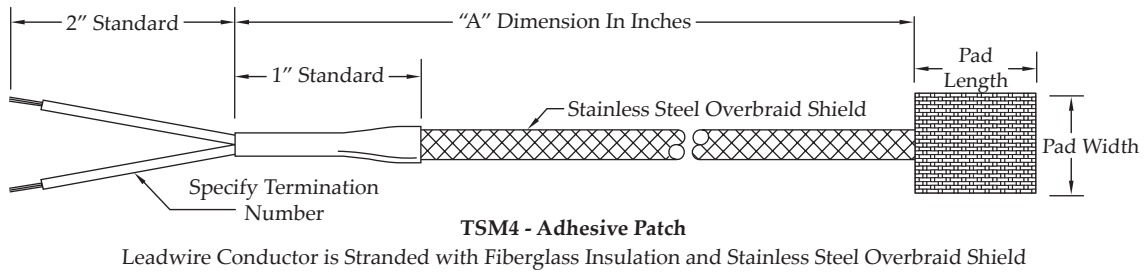
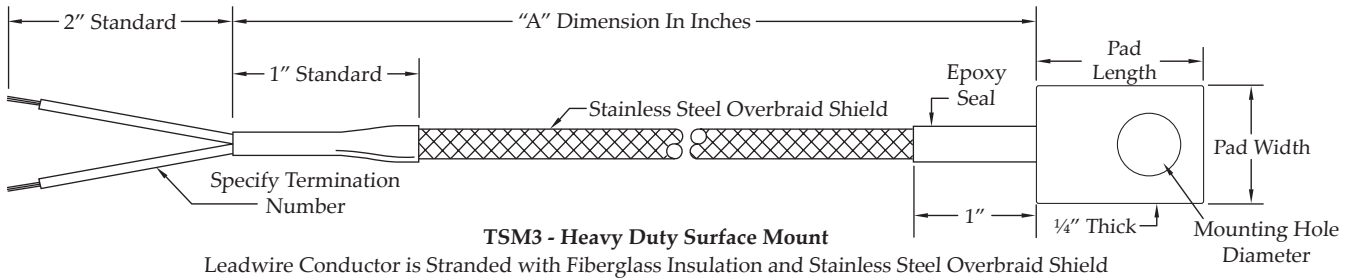

Pad Material

Code	Description
B	Brass
K	Kapton
S	Silicone Rubber

Pad Thickness

Code	Description
D	1/4"
F	3/8"
H	1/2"

Pad Width

Code	Description
00M	Standard 3/4"

Pad Length

Code	Description
010	Standard 1"

Leadwire Options

Code	Description
G	Fiberglass Stranded
H	Fiberglass/Stainless Steel Overbraid Stranded
J	Fiberglass/Stainless Steel Armor Stranded

Termination Options

Termination Number	Description
0	2" Split Leads
1	#6 Spade Lugs
3	Standard Plug
4	Standard Jack
X	Special, Specify

Mounting Hole Options

Mounting Hole Type	Stud Size	Hole Diameter
A	No. 6	.144"
B	No. 8	.169"
C	No. 10	.196"
D	1/4"	.266"
E	3/8"	.390"
P	Mounting Patch	

Part Number Sequence TSM3-JU-BA00M010-024G0C See tables on page 54

TSM3 - J U - B A 00M 010 - 024 G 0 C

Sensor Type Thermocouple Junction Pad Pad Pad Pad "A" Leadwire Termination Mounting Hole & Style No. Type Type Material Thickness Width Length Dim. Option Option Diameter/Patch

NOZZLE THERMOCOUPLES

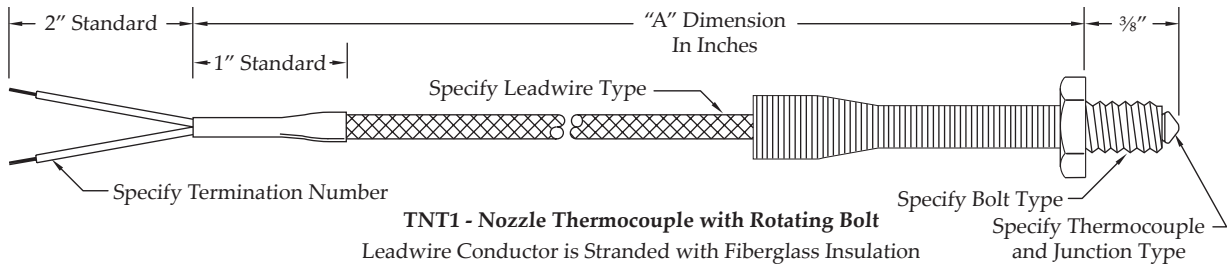

Lead wire Type

Lead wire Number	Description
H	Stranded Fiberglass Leadwire with SS Overbraid
J	Stranded Fiberglass Leadwire with SS Armor

Standard assemblies supplied with stranded leadwire conductor. Solid conductor available upon request.

Termination Options

Termination Number	Description
0	2" Split Leads
1	#6 Spade Lugs
3	Standard Plug
4	Standard Jack
X	Special, Specify

Bolt Options

Bolt Type	Description
S	1/4 - 28
Y	M 6 x 1
Z	M 8 x 1.25

Part Number Sequence

TNT1-JG-036H0Y See tables on page 54

TNT1	-	J	G	-	036	H	0	Y
Sensor Type & Style No.		Thermocouple Type	Junction Type		"A" Dimension	Leadwire Type	Termination Option	Bolt Options

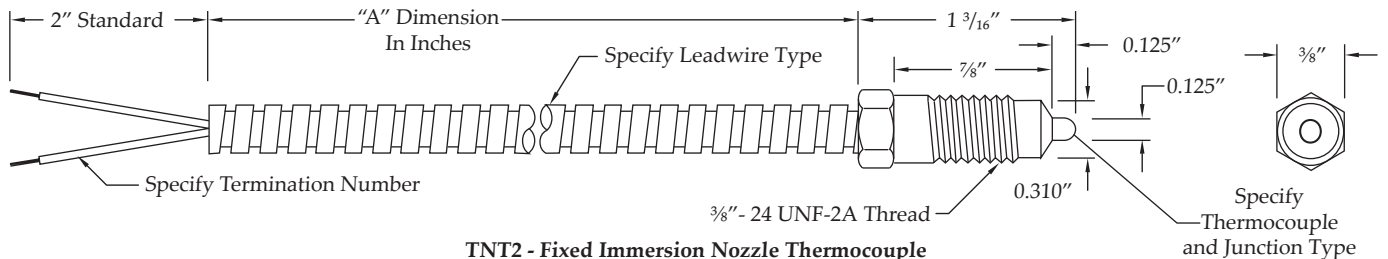

Lead wire Type

Lead wire Number	Description
H	Stranded Fiberglass Leadwire with SS Overbraid
J	Stranded Fiberglass Leadwire with SS Armor

Standard assemblies supplied with stranded leadwire conductor. Solid conductor available upon request.

Termination Options

Termination Number	Description
0	2" Split Leads
1	#6 Spade Lugs
3	Standard Plug
4	Standard Jack
X	Special, Specify

Part Number Sequence

TNT2-JG-048J0Z See tables on page 54

TNT2	-	J	G	-	048	J	0	Z
Sensor Type & Style No.		Thermocouple Type	Junction Type		"A" Dimension	Leadwire Type	Termination Option	Enter Z

NOZZLE THERMOCOUPLES

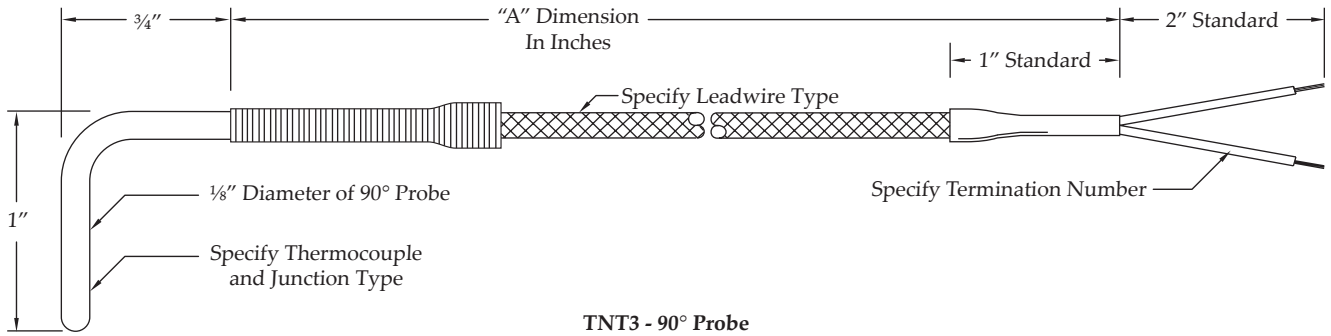

TNT3 - 90° Probe

Lead wire Type

Lead wire Number	Description
H	Stranded Fiberglass Leadwire with SS Overbraid
J	Stranded Fiberglass Leadwire with SS Armor

Termination Options

Termination Number	Description
0	2" Split Leads
1	#6 Spade Lugs
3	Standard Plug

Part Number Sequence

TNT3-JG-072H0Z

See tables on page 54

TNT3	-	J	-	G	-	072	-	H	-	0	-	Z
Sensor Type & Style No.		Thermocouple Type		Junction Type		"A" Dimension		Leadwire Type		Termination Option		Enter Z

SHIM STOCK THERMOCOUPLES

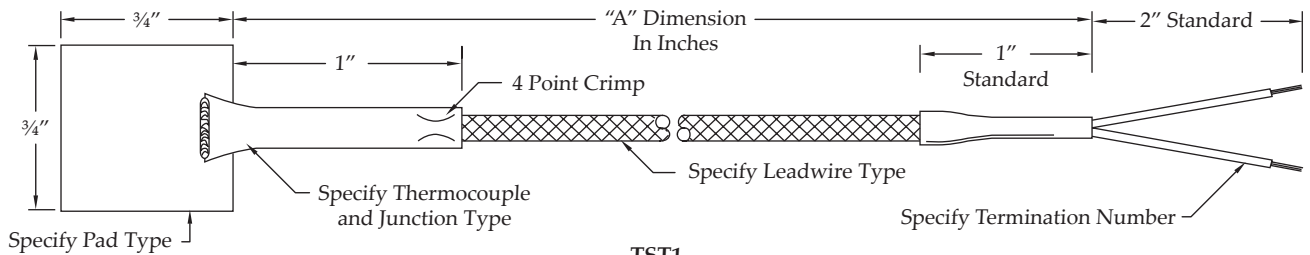

TST1

Leadwire Conductor is Stranded with Fiberglass Insulation

Lead wire Type

Lead wire Number	Description
G	Stranded Fiberglass Leadwire with Fiberglass Jacket
H	Stranded Fiberglass Leadwire with SS Overbraid Shield
J	Stranded Fiberglass Leadwire with SS Armor Cable Shield

Termination Options

Termination Number	Description
0	2" Split Leads
1	#6 Spade Lugs
3	Standard Plug

Pad Options

Pad Type	Description
S	3/4" x 3/4" x .007" Thick
P	1" x 1" x .032" Thick
B	1" x 1" x .060" Thick

Part Number Sequence

TST1-JG-036G0P

See tables on page 54

TST1	-	J	-	G	-	036	-	G	-	0	-	P
Sensor Type & Style No.		Thermocouple Type		Junction Type		"A" Dimension		Leadwire Type		Termination Option		Pad Type

PIPE CLAMP THERMOCOUPLES

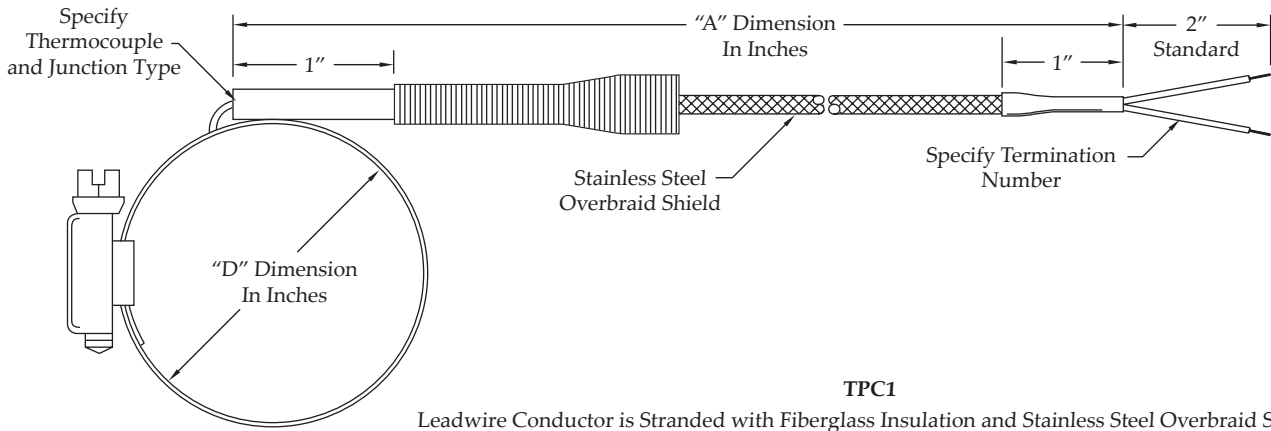

"D" Dimension Options

∅ D Dimension Number	Description
N	½" to ⅞"
1	⅞" to 1 ¼"
2	1 ¼" to 2 ¼"
3	2 ¾" to 3 ⅝"
4	3 ¼" to 4 ¼"
5	4 ¼" to 5 ¼"

Termination Options

Termination Number	Description
0	2" Split Leads
1	#6 Spade Lugs
3	Standard Plug

Part Number Sequence

TPC1-JG-04230

See tables on page 54

TPC1	-	J	G	-	042	3	0
Sensor Type & Style No.		Thermocouple Type	Junction Type		"A" Dimension	"D" Dimension	Termination Option

PIPE CLAMP ADAPTERS

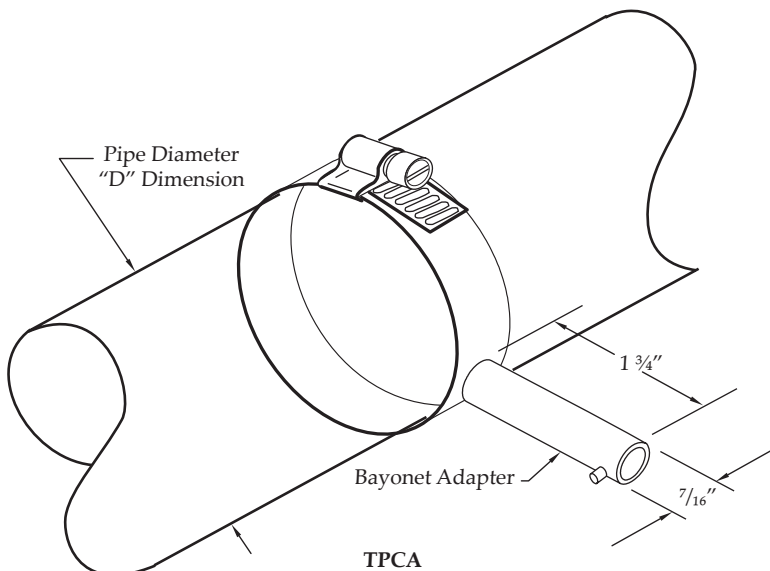

"D" Dimension Options

∅ D Dimension Number	Description
N	½" to ⅞"
1	⅞" to 1 ¼"
2	1 ¼" to 2 ¼"
3	2 ¾" to 3 ⅝"
4	3 ¼" to 4 ¼"
5	4 ¼" to 5 ¼"

Part Number Sequence TPCA-2

TPCA	-	2
Sensor Type & Style No.		"D" Dimension

GENERAL PURPOSE THERMOCOUPLES

General purpose thermocouples are designed for economical use in a wide variety of applications up to 800°F. Sheath material is 304 stainless steel. Type J (Iron-Constantan) calibration is standard. Other calibrations available upon request.

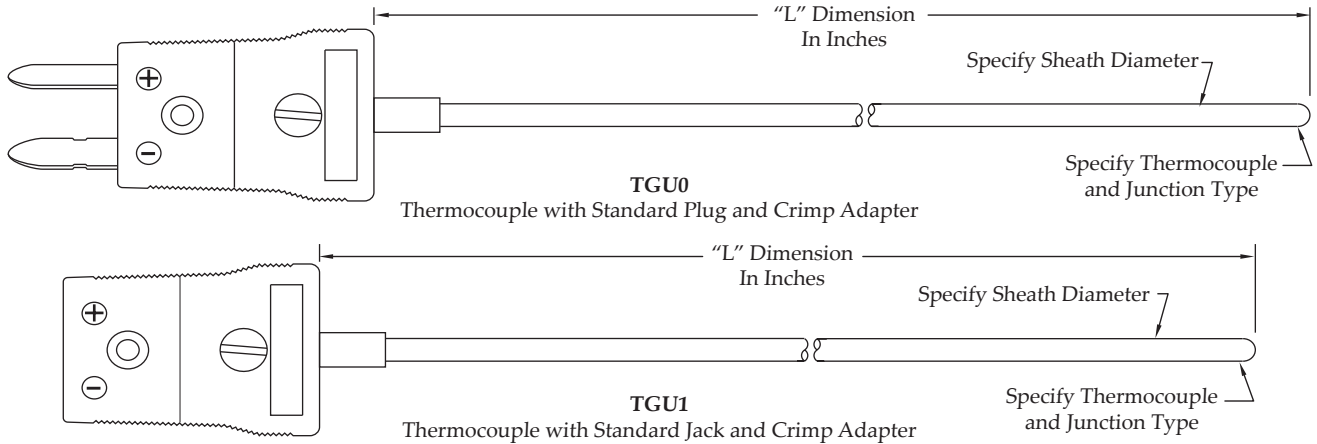

Part Number Sequence

TGU1	-	J	G	-	C (Letter CODE)	12H
Sensor Type & Style No.		Thermocouple Type	Junction Type		Sheath Diameter	"L" Dimension

TGU1-JG-C12H

See tables on page 54

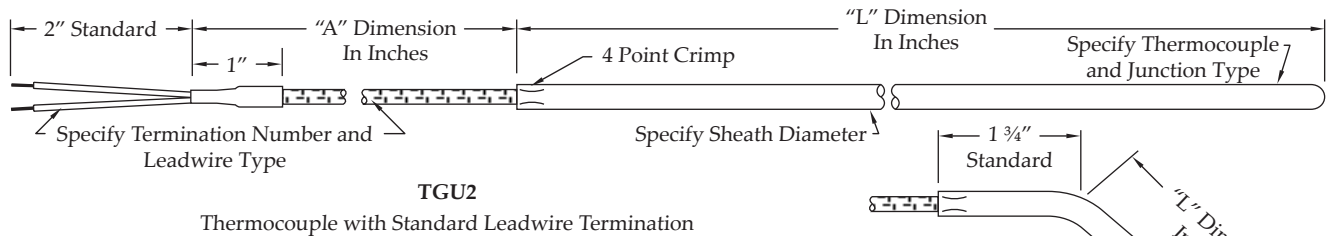

Lead wire Type

Lead wire Number	Description
G	Fiberglass Leadwire with Overall Fiberglass Jacket
H	Stranded Fiberglass Leadwire with SS Overbraid Shield
J	Stranded Fiberglass Leadwire with SS Armor Cable Shield
K	Teflon Leadwire with Overall Teflon Jacket (400°F Max.)

Termination Options

Termination Number	Description
0	2" Split Leads
1	#6 Spade Lugs
3	Standard Plug
4	Standard Jack

Standard assemblies supplied with stranded leadwire conductor. Solid conductor available upon request.

Part Number Sequence

TGU2	-	J	G	-	V = .156"	18D	-	035	H	0
Sensor Type & Style No.		Thermocouple Type	Junction Type		Sheath Diameter	"L" Dimension		"A" Dimension	Leadwire Type	Termination Option

TGU2-JG-V18D-035H0

See tables on page 54

EXTENSION ASSEMBLIES

Standard assemblies are manufactured with fiberglass insulated thermocouple wire and stainless steel armor cable protection. Standard calibration is type "J". Other calibrations and special connections are available upon request.

TEX1 Two BX Connectors with #6 Spade Lugs

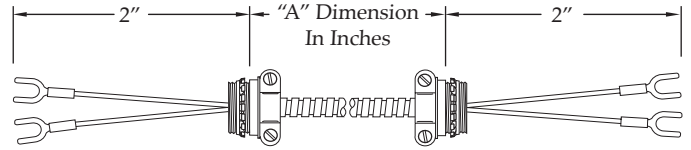

TEX2 BX Connectors with #6 Spade Lugs and Standard Molded Plug

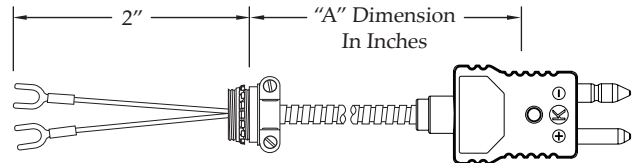

TEX3 BX Connector with #6 Spade Lugs and Standard Jack

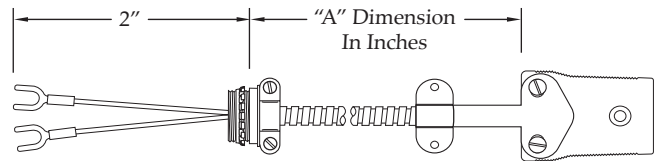

TEX4 Standard Molded Plug and Jack

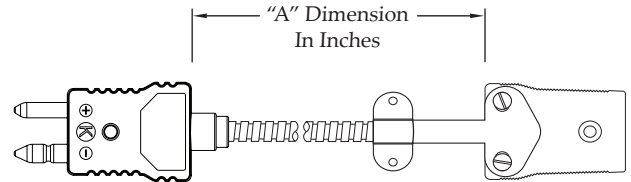

TEX5 Two Standard Molded Plugs

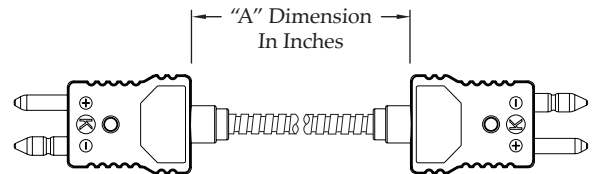

TEX6 Two Standard Jacks

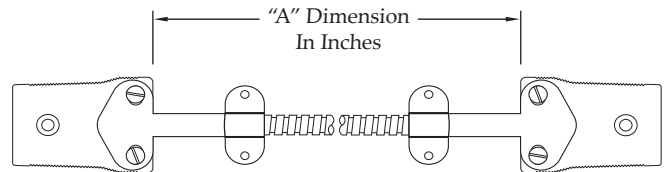

Part Number Sequence

TEX4	-	J	-	048
Sensor Type & Style No.		Thermocouple Type		"A" Dimension

TEX4-J-048

See tables on page 54

ADJUSTABLE DEPTH RTDs

Resistance Temperature Detectors (RTDs) are continuing to expand as a temperature sensor for plastic machinery applications. All the standard plastics thermocouple designs are available in RTD configurations. The standard element is 100 ohm Platinum, 0.00385 $\Omega/\Omega/^\circ\text{C}$, Class B per IEC 751 and DIN 43760 ($\pm 0.1\%$ at 0°C). All assemblies can be specified as 2, 3, or 4 wire configurations. Please specify requirements.

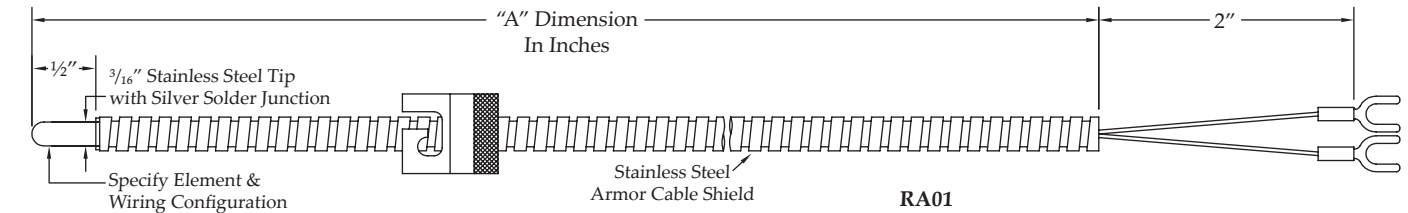
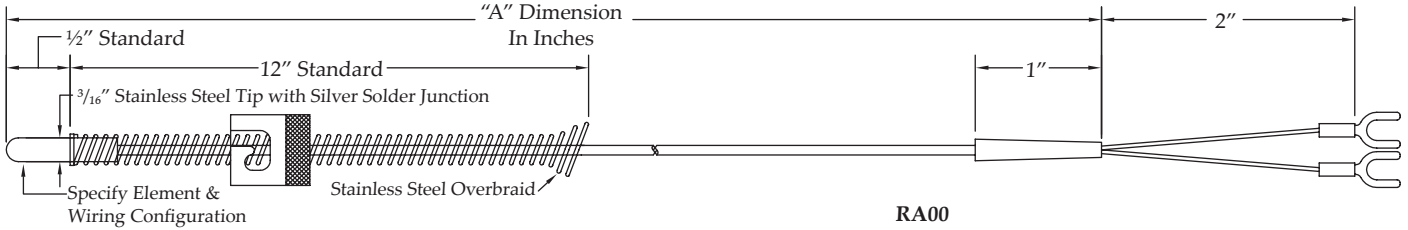

Part Number Sequence						
RA01	-	A	B	-	048	See tables on next page
RA01		Next Page	Next Page		L = 500°F / M = 900°F	1
Sensor Type & Style No.		Element Type	Wiring Configuration	"A" Dimension	Operating Temperature	Termination Type

FIXED BAYONET RTDs

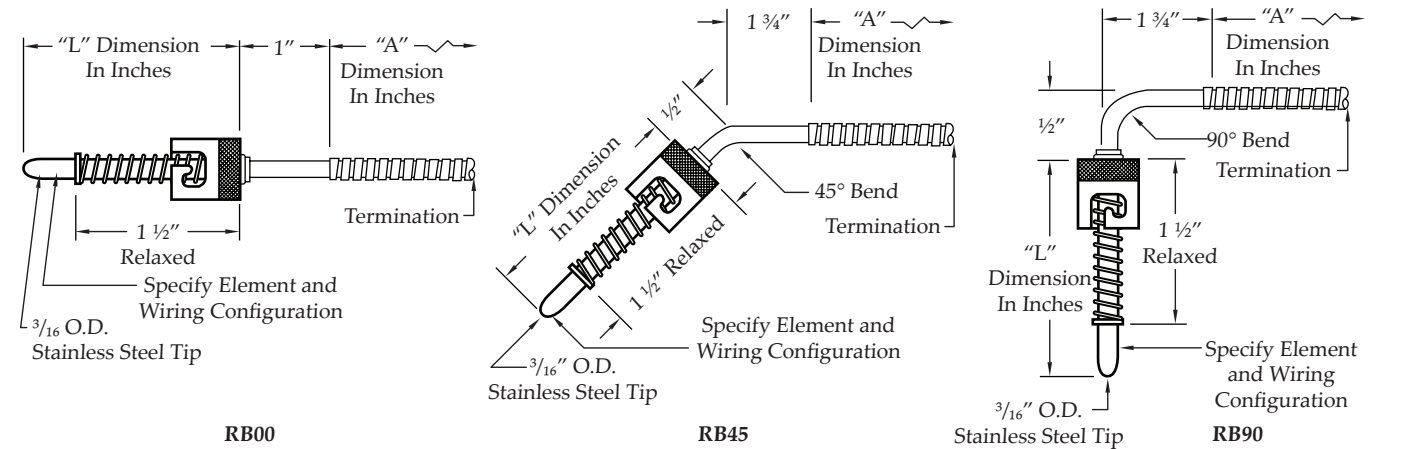

Part Number Sequence						
RB00	-	G	B	-	09F - 022	See tables on next page
RB00		Next Page	Next Page		L = 500°F / M = 900°F	4
Sensor Type & Style No.		Element Type	Wiring Configuration	"L" Dimension	"A" Dimension	Termination Type

Sensors

COMPRESSION FITTING RTDs

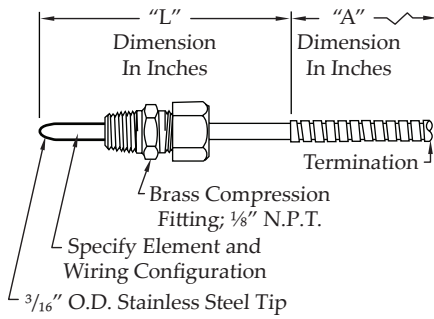

RC00

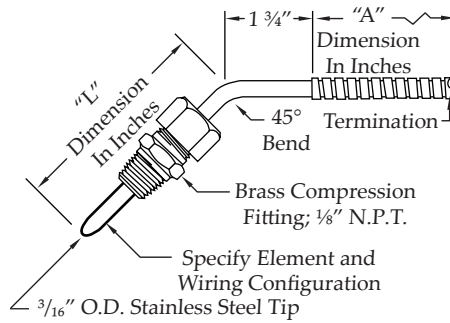

RC45

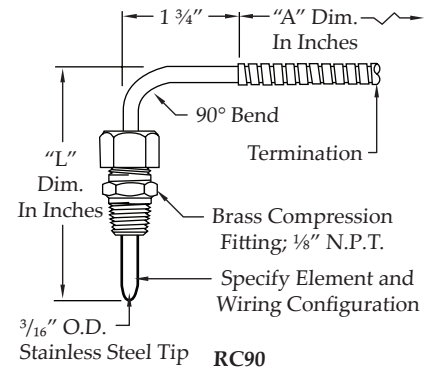

RC90

Part Number Sequence

RC45-ED-04K-028L0

See tables on next page

RC45 - E D - 04K 028 - L 0

RC45 Table Below Table Below See page 54 See page 54 L = 500°F / M = 900°F Options Below

Sensor Type & Style No.	Element Type	Wiring Configuration	"L" Dimension	"A" Dimension	Operating Temperature	Termination Type
-------------------------	--------------	----------------------	---------------	---------------	-----------------------	------------------

RTD OPTIONS

Code	Element Type
A	100 ohm Platinum, Class B .00385 Coefficient
B	100 ohm Platinum, Class A .00385 Coefficient
E	1000 ohm Platinum, Class B .00385 Coefficient
G	100 ohm Platinum, Class B .00392 Coefficient

Code	Wiring
A	Single, 2 Wire
B	Single, 3 Wire
C	Single, 4 Wire
D	Double, 4 Wire

TERMINATION OPTIONS

1/4" Stripped Length

