



closing the loop on thermal solutions

Cast-In Heaters

INTRODUCTION

Durex Industries is a leading edge manufacturer of cast-in heater products for the plastics processing industry. Our products are utilized as the standard for thermal processing on plastics process equipment throughout the world. Engineering of our cast-in products for extrusion applications is based on our years of expertise in development of these products for the largest equipment manufacturers.

Durex has thousands of standard tooling designs available for immediate use. Our in-house tooling capability can rapidly produce any design available on the market. Cast-In heaters for all plastics processing applications including, air and liquid cooled barrel heaters, L-shaped heaters, vent cut out heaters, heat only cast-in barrel heaters, air cooled heaters with shrouds, hollow cast nozzle heaters, and cooling jackets for cast-in barrel heaters.

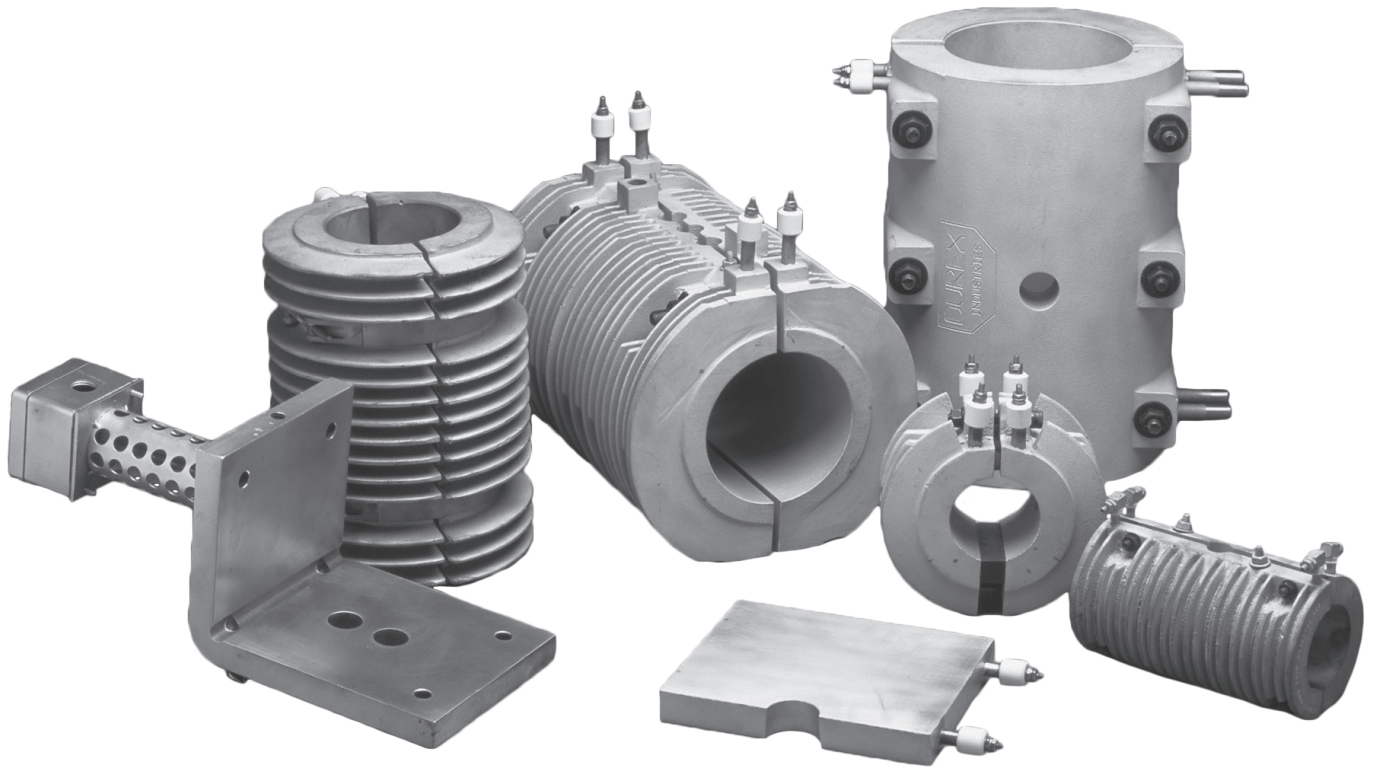

Cast-In Heaters

Typical Applications

- Vacuum forming
- Pressure assist forming
- Drape and press forming
- Barrel and sprue bushing heating
- Hopper heating
- Manifold heating
- Hot runner systems

Cast-In Heaters for Plastics Processing

LIQUID COOLED CAST-IN BARREL HEATERS

Liquid cooled cast-in barrel heaters are the most common cast-in heater design used on plastics extrusion barrels. The liquid cooling tubes run symmetrical to the heater element, which provides a uniform cooling pattern across the body of the casting. This cooling function dissipates heat rapidly from the cast-in barrel allowing a tight control of the melt temperature during operation. The typical liquid cooled design features a single ½" diameter cooling tube of stainless steel or nickel alloy. The tubes can be supplied with no termination and plumbed at the location of the equipment, or other termination options such as cast-in threaded fittings can be supplied to minimize installation time. This cast-in design is also available with a dual cooling function. Although slightly larger in thickness, this design allows for a second cooling tube assembly, which can be employed if the initial cooling line fails due to scale build up or cracking due to corrosion. All Durex cast-in barrel heaters are available with mounting options of stainless steel locking straps or bolt-on clamping construction. Various electrical termination options are available depending on the application or environmental requirements.

Design Features

- High quality Incoloy® or stainless steel cooling tubes
- Available with Dual Cooling for reduced downtime or increased cooling capacity
- Large .430 diameter heating element with large cold pin for rugged termination
- Customized cooling tube options for specific applications
- Mounting to barrel can be bolt-on or strap-on

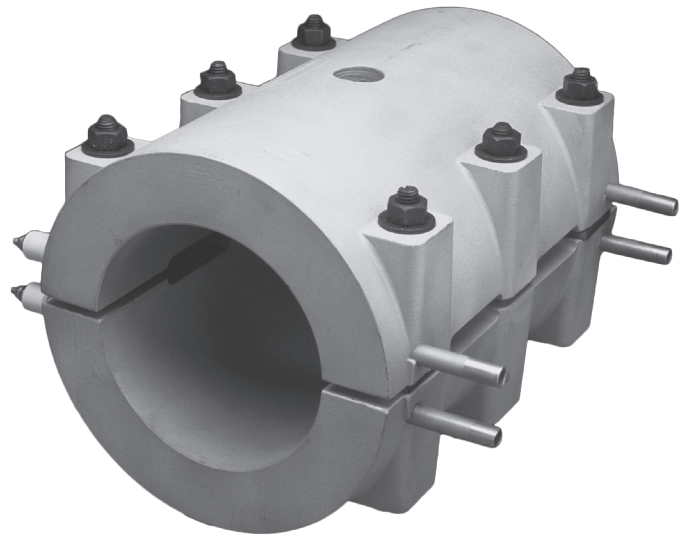

Locking Strap Mounting

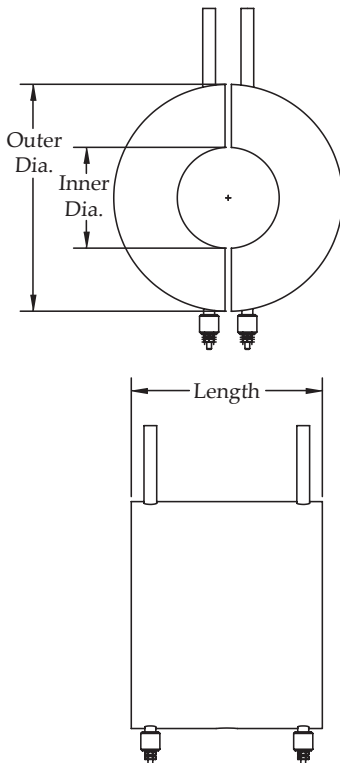

Bolt Mounting

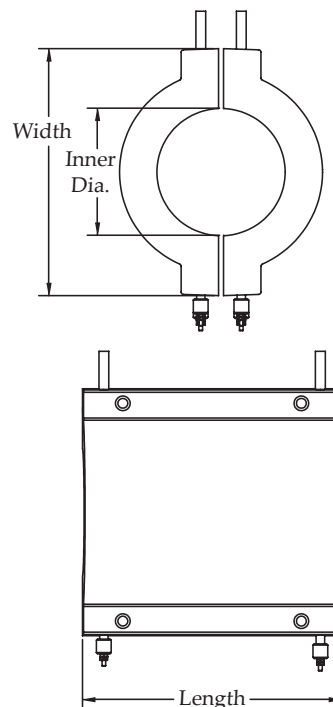



closing the loop on thermal solutions

Cast-In Heaters for Plastics Processing

AIR COOLED CAST-IN BARREL HEATERS

Finned air-cooled cast-in designs provide effective heating and cooling for plastics extrusion barrels. The fin pattern can be supplied as a standard height of 1" or manufactured to a low profile thickness for small extruders or applications requiring rapid cooling. This pattern is designed to allow the optimal airflow around the casting for maximum cooling rates. Typically the forced air for the cooling function is driven by a shroud and blower system that is an integral part of the extruder, however these cast-in heaters can be utilized with an individual shroud and blower assembly for increased cooling control of the individual heater zones. All Durex cast-in barrel heater designs are available with mounting options of stainless steel locking straps or bolt-on clamping construction. Various electrical termination options are available for the air cooled cast-in heater depending on the application and environmental requirements.

Design Features

- Manufactured with various fin patterns for maximum airflow distribution
- Available with low profile fins for space restricted designs
- Mounting to barrel can be bolt-on or strap-on design
- Engineered to fit any existing shroud assembly
- Wide variety of heavy duty electrical termination options

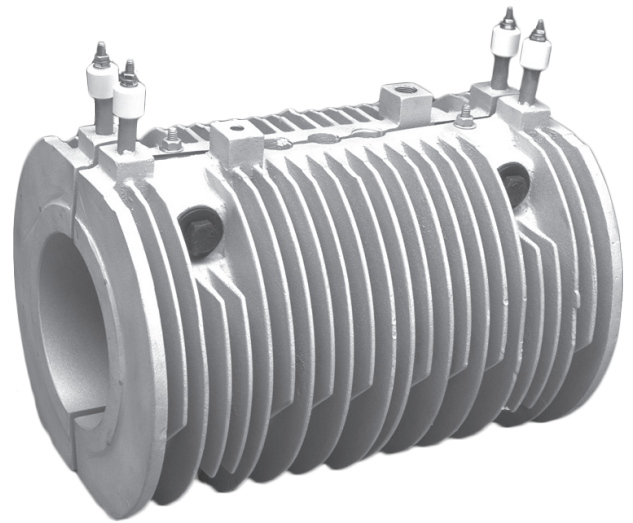

Bolt Mounting

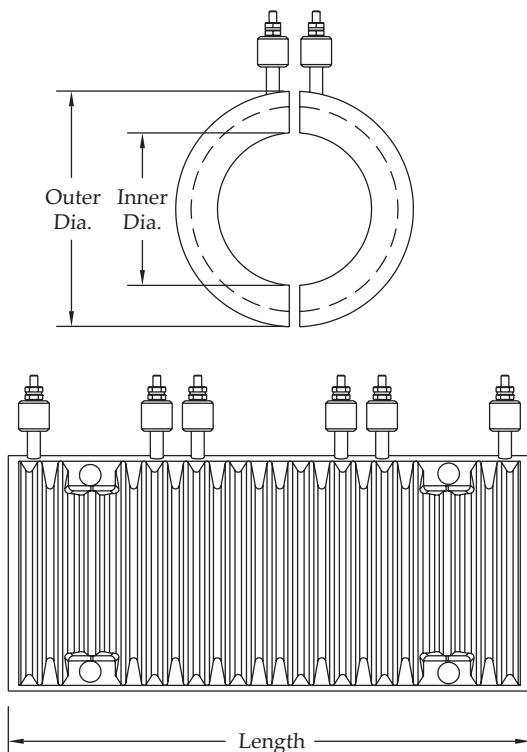

Locking Strap Mounting

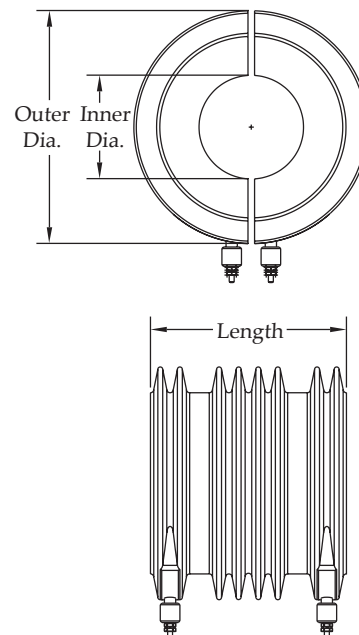

Cast-In Heaters



closing the loop on thermal solutions

Cast-In Heaters for Plastics Processing

AIR COOLED CAST-IN HEATERS with SHROUDS

Individual shroud and blower systems can be used with finned barrel heaters as self contained systems on extruder barrels. The shrouds are manufactured as cast aluminum with bolt mounting or a hinged clamshell design fabricated from stainless steel. The internal design of throat maximizes the airflow over the finned heater body for rapid cooling. Each shroud has a reinforced mounting platform at the orifice for standard sized blowers. Custom mounting options and sizes are available for custom blower applications.

Design Features

- Shrouds are manufactured as cast aluminum or bronze
- Internal air deflector system for maximum airflow
- Vertical or horizontal mounting platforms for blowers
- Custom mounting platforms for customer supplied blowers
- Manufactured to support standard 145 CFM to 495 CFM blowers
- Cool to touch

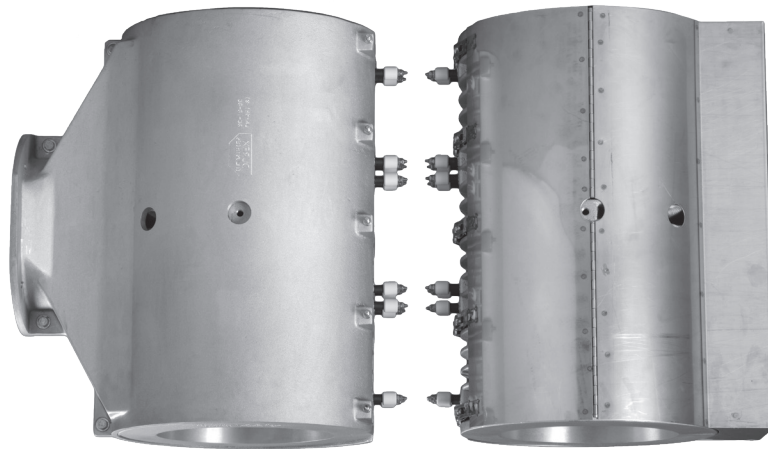
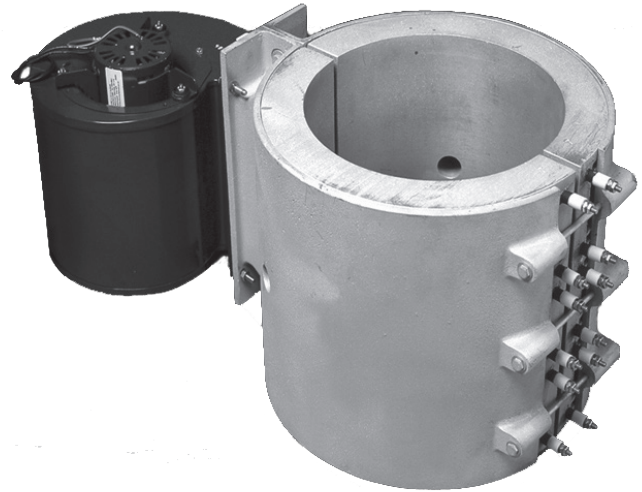

Cast-In Heaters for Plastics Processing

AIR COOLED CAST-IN HEATERS with SHROUDS

Sheet Metal Shroud

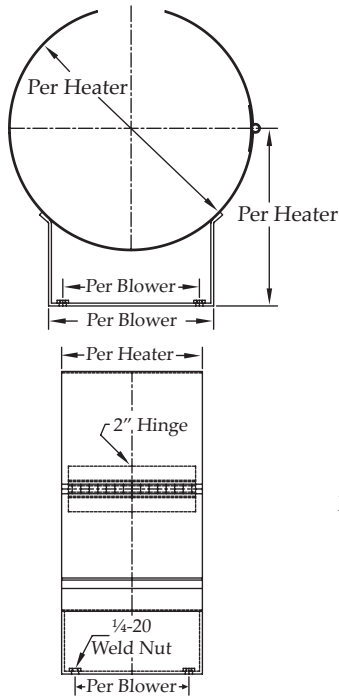

Cast Aluminum Shroud

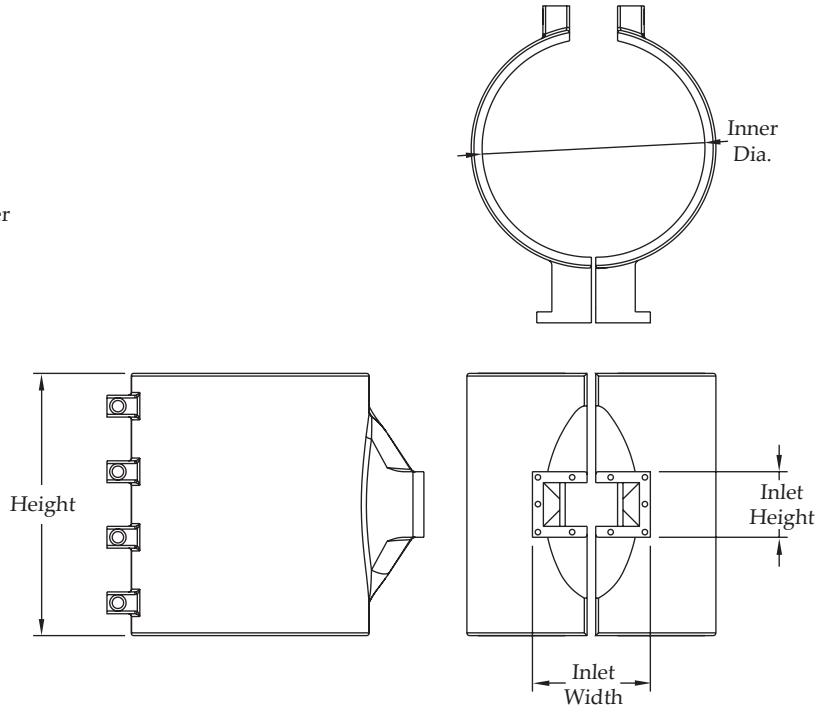

Blower Specifications

- Maximum ambient temperature 104°F (40°C)
- CFM values shown are representative of catalog specifications within ± 15%
- Baked on gray enamel finish
- Additional blowers available on request

Part Number	Voltage	Hz	RPM	Amps	CFM	Outlet (In.)		Dimensions (In.)									
						Height	Width	A	B	C	D	E	F	J	K	L	M
356001	115	60/50	1530	2.9	465	3 5/8	8 1/16	8 13/16	9 7/8	9 1/4	8 3/32	12	3 5/16	9 15/32	5	8 13/16	4 3/8
356006	230	60/50	1570	1.7	495	4 1/8	5 1/8	10 5/16	11 1/8	9 1/2	5 1/4	12	4 7/16	6 5/8	5 5/8	6	5
356010	115	60/50	3160	1.54/1.37	148	2 1/16	3 1/4	5 5/16	5 3/4	7 1/2	3 5/16	6 1/2	3 5/16	4 19/32	3 1/2	3 31/32	2 7/8
356040	230	60/50	1610	0.98/0.93	265	3 11/16	4 1/8	8	9 7/8	7 9/16	4 3/16	10 7/8	3 5/16	5 1/2	5	4 7/8	4 3/8

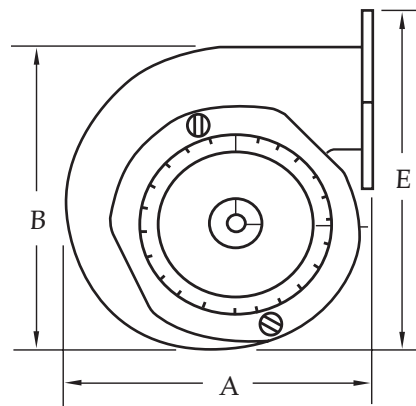
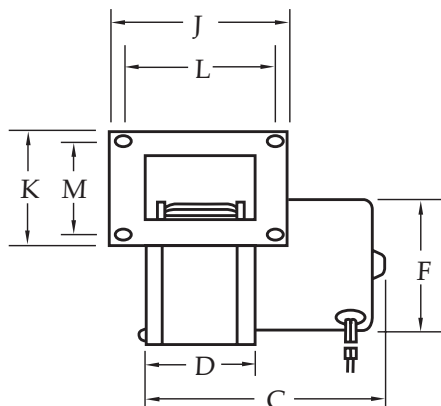



closing the loop on thermal solutions

Cast-In Heaters for Plastics Processing

HIGH VELOCITY AIR COOLED SHROUD SYSTEM

Elegant exterior construction of the high velocity air cooled shroud system enhances the look of your machine or plant location. Durex's highly engineered design saves time and effort through ease of installation. The internal baffle system directs airflow for maximum efficiency, while the external shell heavy-duty wire mesh prevents operator contact with hot shroud surface. The shroud system's reinforced blower mount is constructed to handle high CFM requirements.

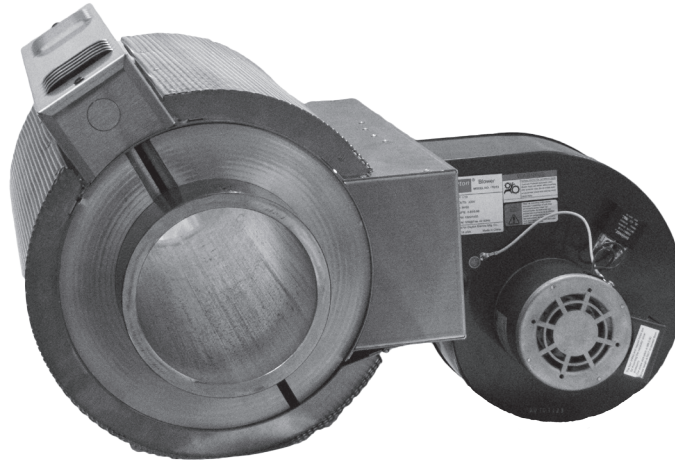

Design Features

Generous Louver System

- Minimizes heat build-up in the electrical terminal area

Heavy Duty Stainless Steel Mesh

- Prevents accidental burns and will not kink or crease

Shroud Assembly Designed to Fit Securely to the Heater Body

- Eliminates walking or shuddering on the barrel

Robust 16 Gauge Stainless Steel Housing and Blower Mount

- Provides stable high CFM service

Sturdy Lock-Up Latches

- Adjust for tight fit to the heater for maximum airflow efficiency

Clamshell Design

- Allows for easy removal of the shroud system with blower still attached

Internal Baffle System

- Ensures optimal and efficient airflow distribution

Cast-In Heaters for Plastics Processing

L-SHAPED SQUARE CAST-IN BARREL HEATERS

The "L" shape cast-in heater design is typically used on square and rectangular extruder barrels, which utilize a twin screw design. In most cases, the high operating temperatures in these applications require these cast-in heaters to be constructed of a bronze alloy, however aluminum alloys are used for applications which do not require the higher watt densities. While the most common design for "L" shaped cast-in heaters consists of heat only, they can be manufactured with cast-in cooling tubes. Typical mounting options include manufacturing the casting with 45° mounting flange which allows the cast-in heaters to be bolted and drawn together on the barrel or the cast-in heater can be supplied with mounting holes machined into the casting to mount directly to the barrel. The most common electrical termination for the "L" shape designs is a junction box mounted on to a vented tower that extends from the body of the casting. The box has a gasket for moisture resistance and can also be supplied with explosion proof specifications. The junction box can also be cast directly onto the heater. High temperature leadwire with a heavy-duty bronze braid is also available upon request.

Design Features

- Flange ear or drilled holes for mounting to the barrel
- Durable cast-in vented towers for terminal box mounting
- Manufactured in aluminum alloy for lower temperature applications
- Cooling tubes can be cast-in for liquid cooling capacity
- Machined holes for transducers and thermocouple locations

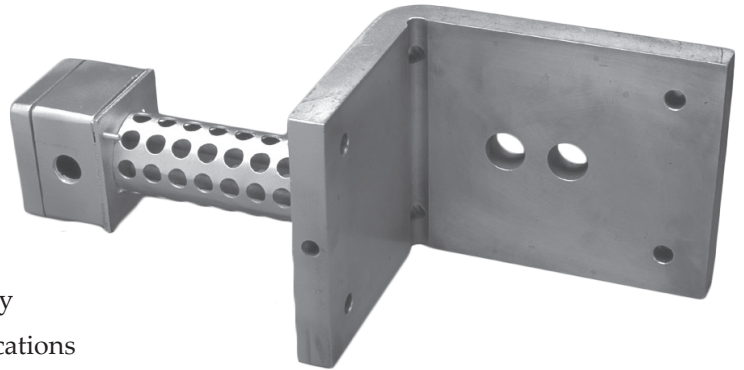

Flange Ear

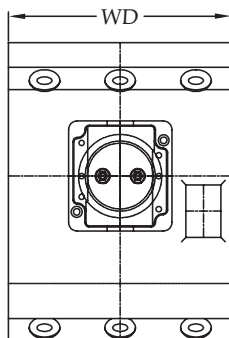
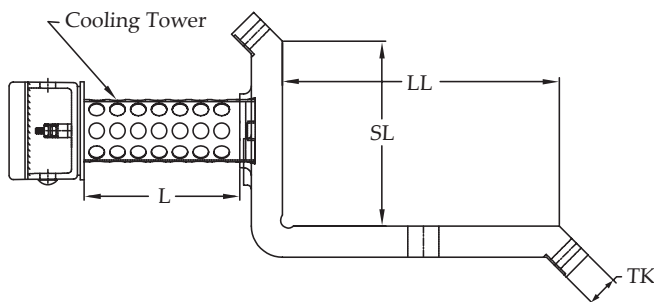

Drilling Holes

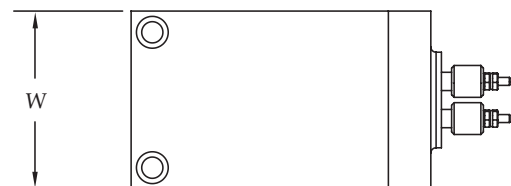
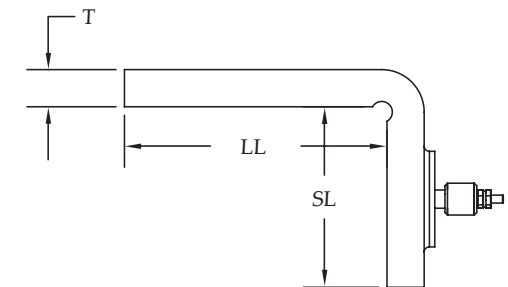

Cast-In Heaters for Plastics Processing

VENT CUTOUT CAST-IN HEATERS

Special sections of the cast-in extruder barrel such as a vent or feed throat require custom modifications to fit properly. These Vent/Cutout Cast-In Heaters are designed with element locations that maximize heater performance, but allow for special machined sections that could not be added to a standard barrel design.

Design Features

- Designed for uniform heat of vent zone
- Available in aluminum or bronze
- Manufactured per customer specifications
- Available with standard terminations

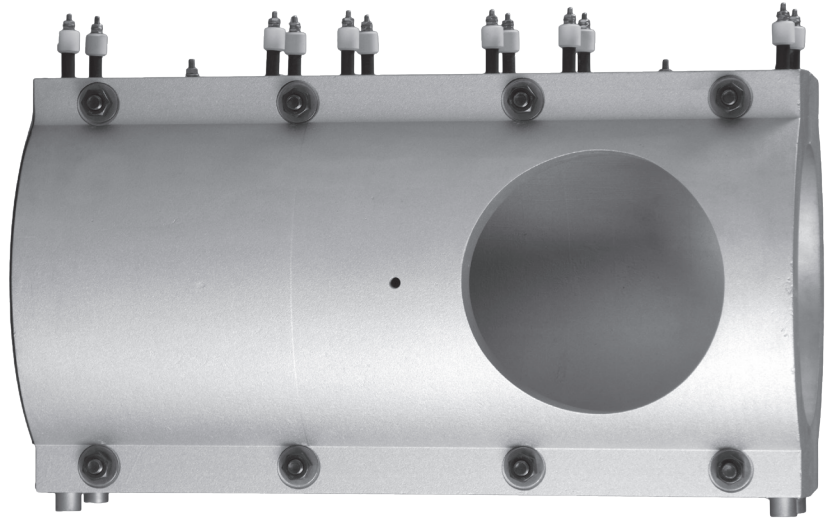

Bolt Air Cutout

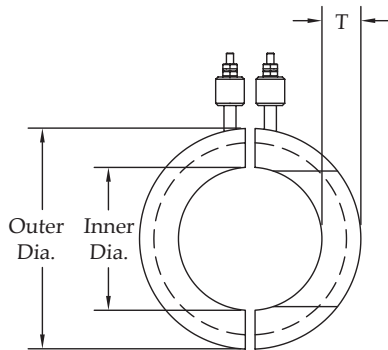

Bolt Air Vent

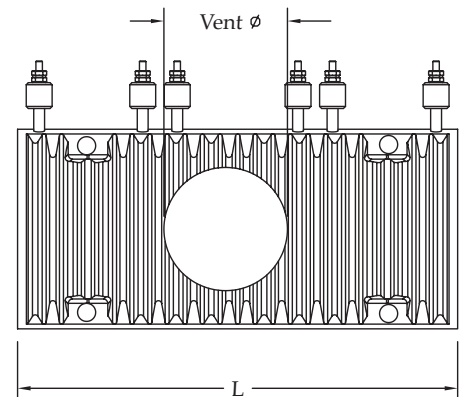
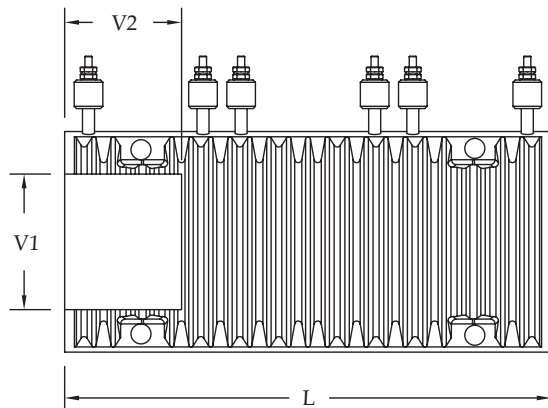
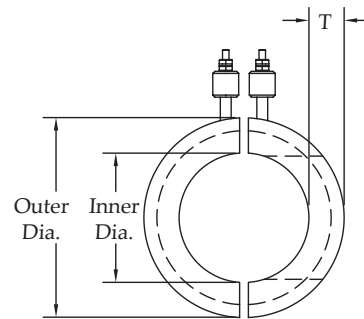



closing the loop on thermal solutions

Cast-In Heaters for Plastics Processing

HEAT-ONLY CAST-IN HEATERS

Although not a common design, heat-only cast-in barrel heaters are available primarily with the stainless steel mounting strap option. This design is standardly 1" thick and can be used with all standard electrical terminations that Durex offers. The cast-in heat-only design can be used on piping areas that are typically more difficult to heat such as elbows and joint areas. The cast-in heater can also be cast directly onto pipe elbows or other areas to produce an integral heated part in specific applications such as feed pipes or heat exchangers. Designs are available in both aluminum and bronze alloys.



COOLING JACKETS FOR CAST-IN HEATERS

Cast-in cooling jackets are manufactured for specific applications that do not require heat but require a uniform cooling source, which can be controlled.

The cooling jacket typically is 1" thick with ½" cooling tubes that are either stainless steel or Incoloy[®] depending on the application. As with other liquid cooled designs, all standard cooling tube terminations are available.

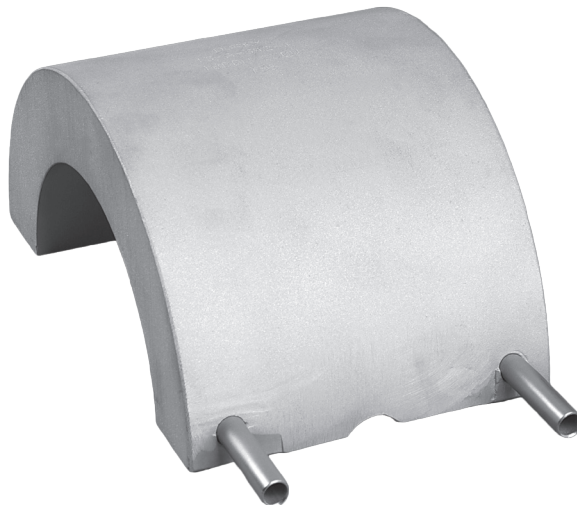



closing the loop on thermal solutions

Cast-In Platen Heaters

Manufactured from aluminum or bronze alloys, the platen heater consists of a tubular heating element that is designed and formed to provide maximum efficiency and temperature uniformity on the working surface of the casting. The platens can also be designed with integral cooling tubes or as stand alone cooling platens for chilling applications. The working surface of the platen heater can be supplied with various machined finishes to customer specifications. Durex can also provide a ground surface for stringent flat surface requirements. In addition, surface coatings of electroless nickel, Teflon®, and hard-coat anodizing can be applied per application requirements

Mounting options can be cast in the design of the platen or machined as a secondary process. These options include threaded stand-offs, cast-in anchors, ribbed back supports, tapped holes, and mounting slots. Electrical terminations can be threaded terminals, flexible wire, three-prong electrical plugs, or NEMA housings. Durex manufactures all platen designs to customer specification. Engineering assistance is available to help create a new design or modify your existing one using our FEA analysis profiles and rapid prototype simulations.

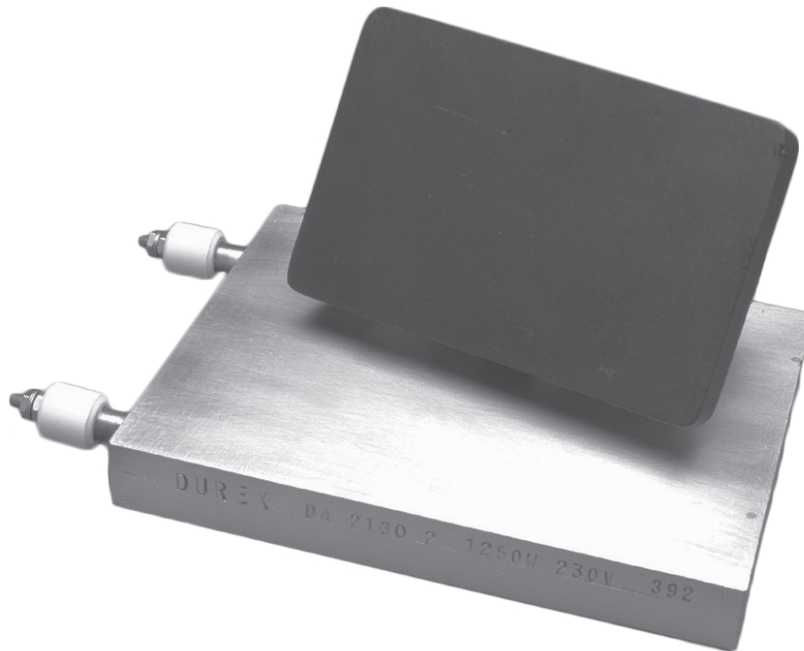

Cast-In Heaters

Design Features

- Aluminum or bronze cast alloys
- Custom machined surfaces
- Surface coatings of electroless nickel, Teflon®, or anodized
- Liquid cooling option
- Flexible electrical terminations
- Single or three-phase electrical circuits
- Custom mounting options

Typical Applications

- Heat transfer presses
- Foodservice equipment
- Die heaters
- Packaging equipment
- Commercial pre-heaters



closing the loop on thermal solutions

Cast-In Ring Heaters

Cast-in ring heaters are used in various punching, forming, sealing, and warming applications. They are also a direct replacement for mica style ring heaters. The cast-in heating element delivers a robust construction in a low profile design that is well suited for continuous production applications. The ring design can include mounting features such as cast mounting tabs, threaded inserts, and drilled holes. Ring heaters can also be designed as die sets for heated stamping applications.



Cast-In Heaters

Design Features

- Low profile construction as thin as ½"
- Engineered to replace any existing ring design
- Available in aluminum or bronze
- Custom electrical plug terminations
- Cast-in anchors for heavy duty threaded mounting holes
- Precision machining of surfaces and mounting holes
- Flexible lead wire terminations of any length



closing the loop on thermal solutions

Custom Cast-In Heaters

Durex Industries custom cast-in heated parts are designed to eliminate the need for multiple part sourcing and assembly, as well as provide a more uniform thermal process to your application. Our engineering staff can design a part that is “plug and play” for your application. Whether you have a basic concept or a complete drawing with specifications.

Hot Melt Adhesive Systems

Cast-in heaters are a unique heat source that can be adapted to many high-performance applications. Cast-in heaters are basically a heated part or tool that can be conceptualized and integrated as a component in a variety of equipment such as hot melt adhesives, foodservice, medical, packaging, paint spraying, semiconductor, and process pipelines.

The heating element is cast into aluminum, bronze, or iron and is an integral part of the final metal part, therefore operating at maximum heater efficiency, and eliminating the need to supply a heater as a second component attached to a machined component.

Durex engineering can assist with the process of specifying cast-in heated parts to fit your application. Additional components such as terminal boxes, threaded fittings, special tubing, or temperature sensors can be cast-in as system requirements dictate.

Cast Heater technology can be designed as a turnkey heating or cooling thermal solution that optimizes the temperature profile in GC headspace auto-sampler, DNA replication, and other critical instrumentation.

Design Features

- Three dimensional cast aluminum assemblies
- Operating temperature < 450°C (842°F)
- Aluminum alloys 170.1, 319 or 356
- Precision machining
- Integral RTD or thermocouple sensors

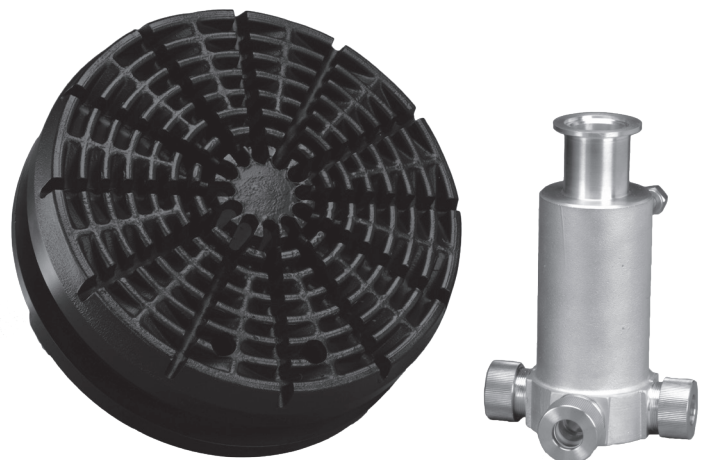
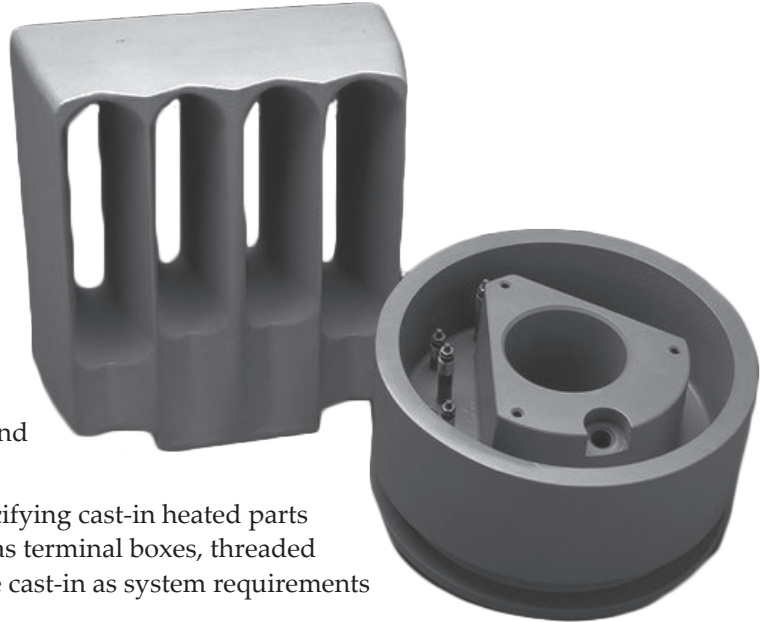

Cast-In Heaters

CAST-IN CIRCULATION HEATERS DFX SERIES*

The Cast Circulation Heater DFX Series are compact, electric, in-line circulation heaters designed to quickly and safely heat liquids and gases. These cast-in-aluminum circulation heaters heat fluids indirectly providing a clean heating environment. The design also protects oils and other viscous fluids from thermal breakdown often found in direct immersion applications. The heater elements are protected from corrosive attack and yet provide rapid heat up of process fluids. The excellent thermal conductivity of aluminum provides fast thermal response and excellent controllability. Optional dual fluid path designs in the Series 550 and 750 provide heat/cool capabilities for precise solvent, volatiles, and viscous liquid temperature control. Or the dual tubing can be used to double the flow rate, halve the pressure drop, or be used in a heat/heat configuration.

*For more information on Durex Cast Circulation Heaters, please refer to the Process Heater section.

Design Features

- Low mass design for quick thermal response and excellent controllability.
- Cast aluminum heat exchanger body for indirect fluid heating
- Seamless 316 Stainless Steel flow tubing
- 3000 psi rating
- UL® recognition & certified ex/enclosures
- Standard NEMA 1 enclosure



Cast-In Heaters

Applications

LIQUIDS

- De-ionized water
- Water, glycol, and CIP solutions
- Lube and heat transfer oils
- Adhesives, resins, and other viscous fluids
- Temperature sensitive inks, coatings, and paints

SOLVENTS

- ACT
- EKC
- MEK
- NMP
- Others

GASES

- Nitrogen & similar gases
- Supercritical cleaning
- Steam generation & superheating
- Sterilization gases
- Other non-flammable gases

Cast-In Heater Terminations

Electrical Terminations

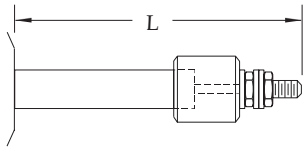

TYPE S

10-32 threaded screw terminal with ceramic insulator. Included nuts and washers.

Type S standard for cast-in heaters. 6-32, 8-32 and metric sizes also available.

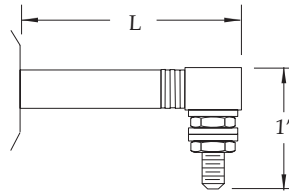

TYPE A

Right angle terminal block seated on mica washers with 10-32 threaded stud. Included nuts and washers.

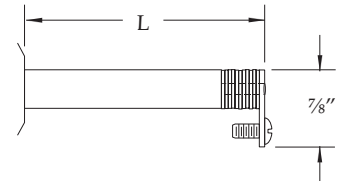

TYPE R

Screw lug terminal seated on mica washers and welded to pin. Includes 8-32 screw for wire connection.

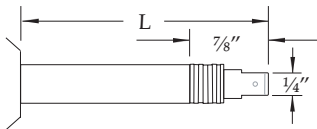

TYPE D

Quick-disconnect spade lug with 1/4" blade welded to pin. Other blade sizes available upon request.

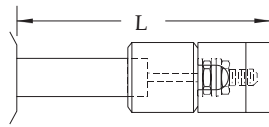

TYPE T

Ceramic insulator with ceramic top for insulation of electrical connections. Includes complete Type "S" termination with 10-32 threaded stud.

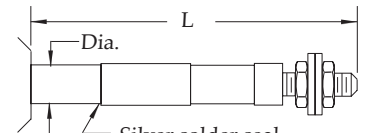

Silver solder seal

TYPE HS

Ceramic to metal hermetic seal is silver soldered directly to heating element for moisture-proof termination. 10-32 screw terminal includes nuts and washers.

Dia.	L	Thread
.430	1 1/8"	1/4-28
.315	1 3/8"	10-32
.250	1 5/8"	8-32

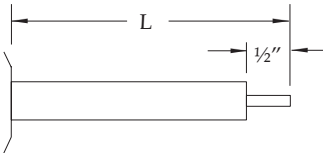

TYPE P

Plain pin for field attachment of termination. Pin length is 1/2" standard.

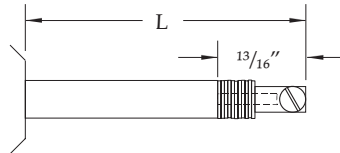

TYPE L

Terminal lug with 10-32 screw is welded directly to heater pin. Can be oriented straight or at right angle.

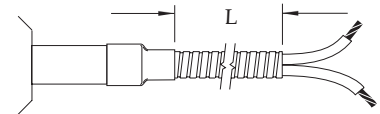

TYPE C

Flexible armor cable for abrasion resistance with high temperature leadwire attached to heating element. Specify L dimension when ordering.

Cooling Tube Terminations

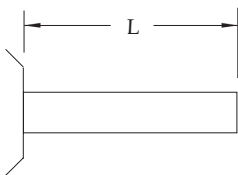

TYPE C1

Plain cooling tube cut to standard 3" length extending from heater. Specify longer length if required.

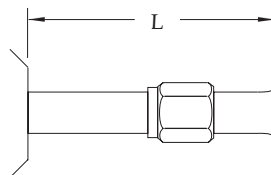

TYPE C2

37° Flare nut fitting allows for cooling tube connection to compression fitting.

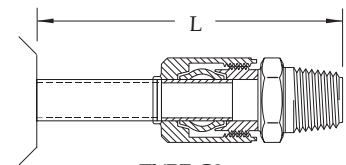

TYPE C3

Compression fitting mounted directly to cooling tube provides seal for high pressure hook up. Available in standard 3/8" and 1/2" NPT. 3/8" Dia. #55-0010 1/2" Dia. #55-0011

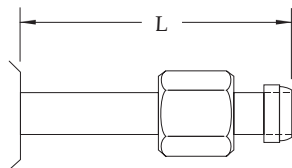

TYPE C4

Brazed seal with locknut provide an effective seal for high pressure applications. Mating fittings available upon request.

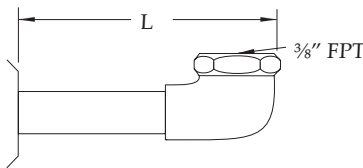

TYPE C5

Brazed angle fitting mounted directly to cooling tube with right angle 3/8" FPT as standard. Specify L dimensions.

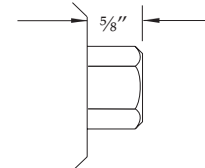

TYPE C6

Cast-in fitting with standard 5/8" FPT for quick installation of cooling lines with no additional fittings.

Cast-In Heater Protective Housings

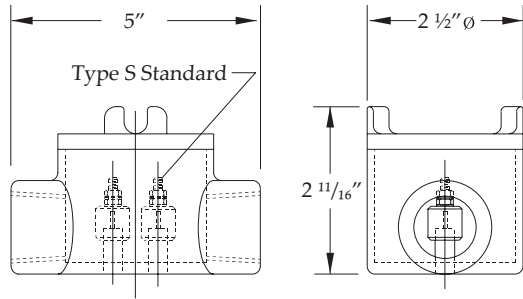

TYPE B1

Explosion proof cast iron housing with 1/2" NPT double hub. Single phase design shown. Larger housing for 3 phase design also available.

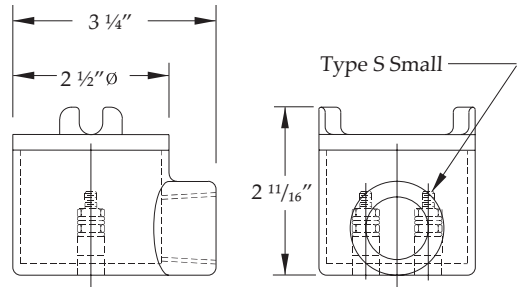

TYPE B2

Explosion proof cast iron housing with 1/2" NPT single hub. Single phase design shown. Larger housing for 3 phase design also available.

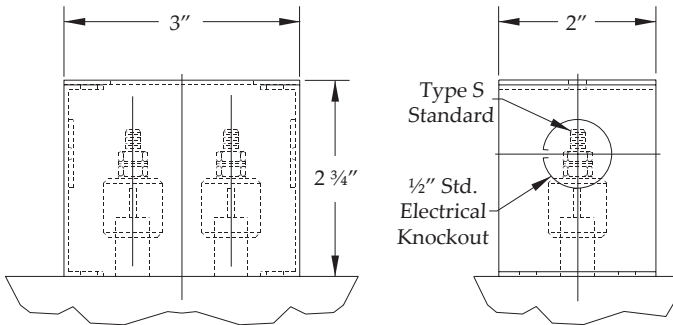

TYPE B3

Standard size stainless steel sheet metal box with two 1/2" electrical knockouts. Other sizes and types available.

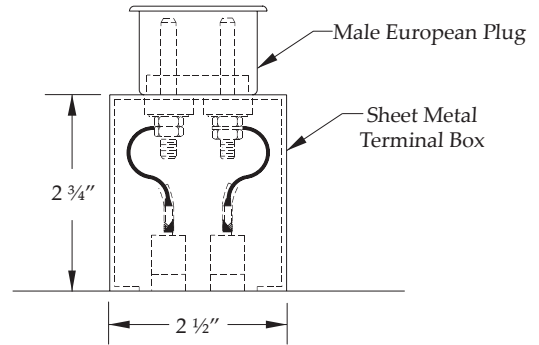

TYPE B4

Stainless steel terminal enclosure with male ERGE plug mounted on top. Mating connections available upon request.

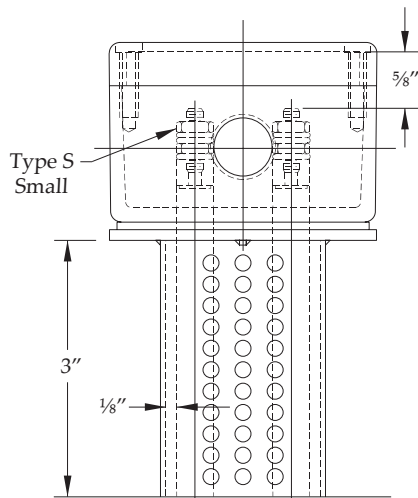

TYPE B5

Die cast aluminum enclosure with 1/2" or 3/4" threaded electrical connections mounted to vented cooling tower. Other sizes and types available for single and 3 phase designs.

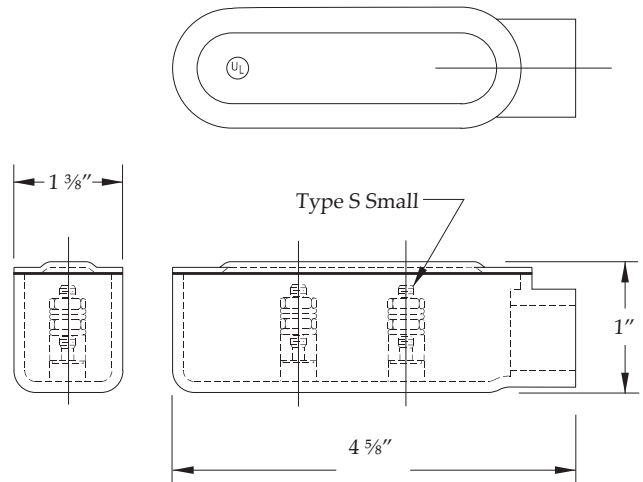

TYPE B6

Explosion resistant box with 1/2" NPT single hub, designed for low profile applications. Single phase only. Different hub configurations are available.



closing the loop on thermal solutions

Cast-In Heater Specifications & Special Services

Cast Materials	Max. Operating Temperature
Aluminum 443	800°F (427°C)
Aluminum 319/356	700°F (371°C)
Bronze / Copper alloys	1400°F (769°C)
Iron	900°F (482°C)

If required, other cast materials are available.

CAST PROCESS

Cast-In perm-molded system uses steel permanent molds. No bake sand system for special castings and short production runs.

MACHINE FINISH

CNC machining is performed for tight tolerances and complex configurations. Milled finishes are provided per specification. Belt sanding, lapping and polishing available to meet application specifications.

Standard Machine Finish Range: 64-125 rms

Fine Finish Per Specifications: 8-32 rms

Standard Flatness:

Belt Sanded: .015

Milled: ± .005

Lapped: .001

HOLES, CUTOUTS, THERMOWELLS

Mounting or clearance holes, cutouts, and thermowells for inserting temperature measurement probes, cast-in or machined per your specifications.

INSERTS

Threaded studs, precision component parts, bushings and special design parts cast accurately in place.

ELECTRICAL

Resistance tolerance NEMA standard +10% -5%.

Voltages:

Element Diameter	.200	.260	.315	.430	.475
Maximum Volts	240	240	277	600	600

(Three phase available on large heaters.)

Maximum watt densities depends on size and application.

Consult a Durex engineer.

UL COMPONENT RECOGNITION

DA series cast-in heaters are recognized per file E110394.

INSPECTION / TESTING

- Electrical per UL 499 and UL 1030
- Canadian Standard C22.2 No. 72
- Dimensional per specifications using
- Coordinate Measure Machine
- Quality standard per MIL-Q_9858A

RADIOGRAPH (X-RAY)

Confirmation of internal element configuration and casting soundness available through x-ray.

PLATING / COATING

Electroless nickel plating, anodize, Teflon® coatings and special blasted surfaces are available per customer specification.

PRESSURE TESTING

High pressure leakage testing done in-house per application requirements.

HEAT TREATING

Stress relieving and aging through heat treating available as required.

CMM INSPECTION

Coordinate Measuring Machine used for precision quality control of tight tolerance machining requirements.

HELIUM LEAK

Detect microleakage from casting body.

TEMPERATURE UNIFORMITY

Confirm heat uniformity across the finished surface.

CLASS 1000 CLEAN ROOM

Clean room assembly and packaging per class 1000 standards.

SOLIDWORKS 3D MODELING

Engineering software provides 3D models of proposed or existing product designs.

CUSTOM PACKAGING

Customer specific packaging for delicate surfaces, large multi-product shipments, or long term storage.

LIFE CYCLE TESTING

Life cycle test chamber for long term testing of uniformity and performance characteristics.

MATERIAL CERTIFICATIONS

Precise records and certifications on materials which require traceability to specific standards.

SENSOR CALIBRATION

NIST traceable calibration lab for calibration and certification of any temperature sensor requirements.

FEA ANALYSIS

Preview of proposed design construction using FEA analysis.

Cast-In Heater Installation & Operation Guidelines

1. Always ensure that cast-in heaters are properly mounted to the application to avoid warping of flat heaters or “walking” of barrel heaters. After the initial start-up, retighten the heater mounting system to assure complete surface contact. Periodically check bolts or straps and tighten as required maintenance.
2. Tighten all liquid cool connections securely to avoid rupture from internal steam pressures. Cast-in C6 fittings or brazed connections are the most reliable. Properly maintain these connections to avoid leaks that will destroy the heater. Do not operate heating and cooling simultaneously to avoid thermal shock of the cooling tubes.
3. It is recommended that water used for liquid cooling applications be treated to avoid corrosion and hard water deposits that will clog the cooling tubes over time.
4. Install proper temperature control prior to operation of the heaters to ensure protection from over-temp situations which may damage the heater or equipment. Periodically changing temperature sensors is good preventive maintenance.
5. Electrical terminals must be properly insulated and made tightly to ensure safe operation. All heater installations must be properly grounded. All electrical terminations must be made per applicable Electrical Safety Codes and O.S.H.A. regulations.
6. Do not operate the heaters outside of the rated voltage and temperature of the design. This will cause the heaters to fail.
7. Always disconnect the electrical power to heaters prior to service.

Electrical Data

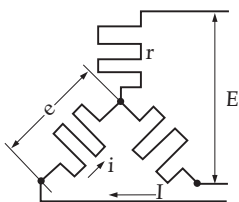

Wye or Star Connection

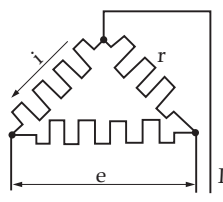

Delta Connection

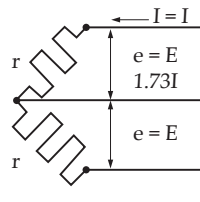

3-Phase Open Delta

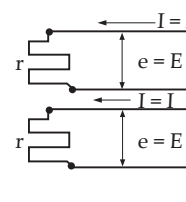

2-Phase 4 Wire

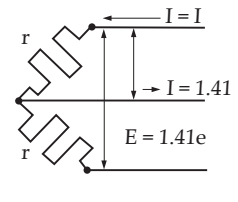

2-Phase 3 Wire

The energy put out by a heating unit is measured in watts.
The power factor is always unity.

Single Phase, $W = I^2 = EI$
 Three Phase Delta, $W = 3EI = 1.73 EI$
 Three Phase Wye, $W = 3eI = 1.73 EI$
 Two Phase 4 Wire, $W = 2I^2R = 2 EI$
 Two Phase 3 Wire, $W = 2I^2R = 2 EI$
 (Voltage between outside wires = $1.41e$)

$$\text{Phase Amps} = I = \frac{W}{E \times \text{PF}}$$

$$\text{A.C., 3 Phase Amps} = I = \frac{W}{1.73 E \times \text{PF}}$$

$$\text{A.C., 2 Phase 3 Wire: Middle wire amps} = \text{Amps in outside wire} \times 1.41$$

W = Power, Watts
 E = E.M.F. Volts
 I = Current, Amperes
 R = Resistance, Ohms
 PF = Power Factor
 $\text{Amps} = I = \frac{W}{E} = \frac{E}{R}$

OHMS LAW

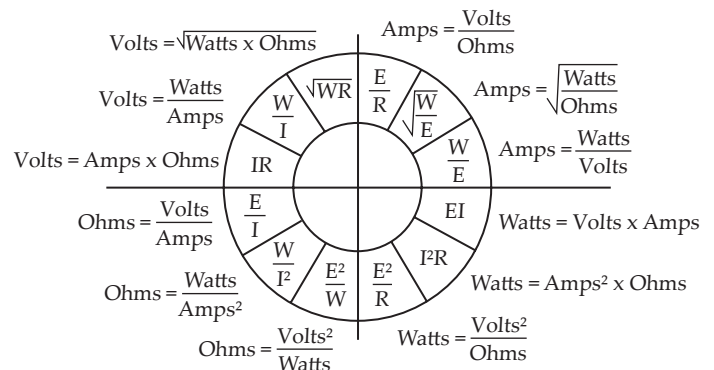



closing the loop on thermal solutions

Cast-In Heaters

CAST-IN HEATER TEMPLATE

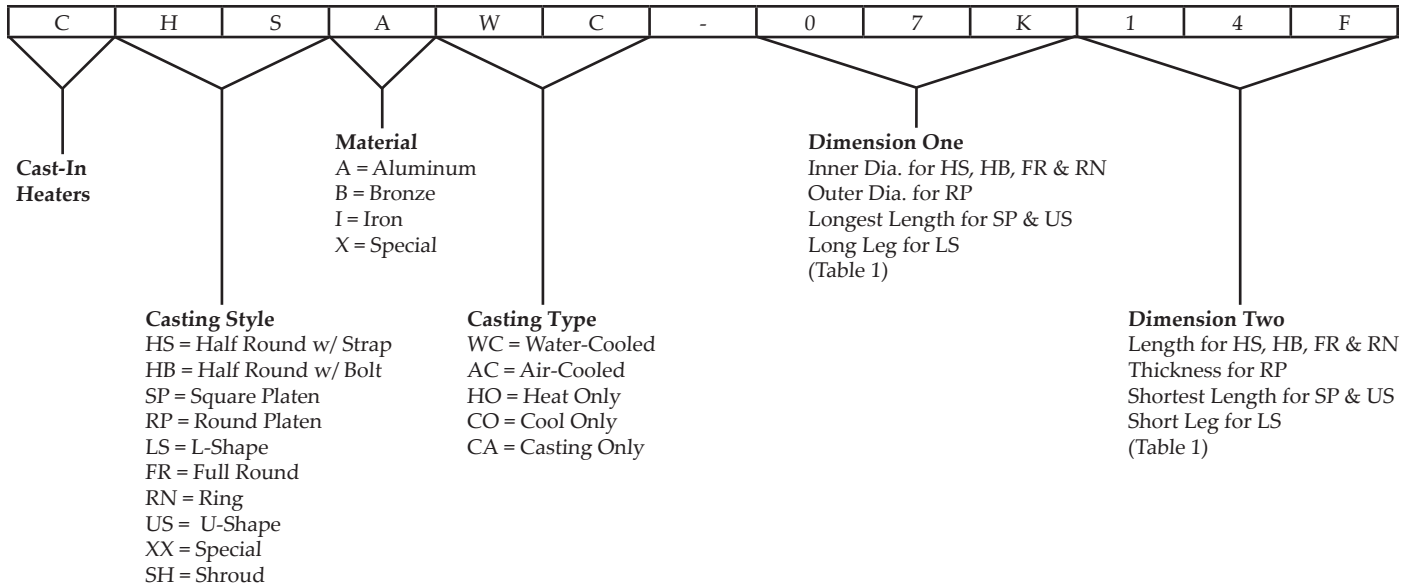

Table 1

Dimension One & Two Codes				
Frac.	=	Dec.	=	Code
0	=	0	=	0
1/16"	=	0.062"	=	A
1/8"	=	0.125"	=	B
3/16"	=	0.188"	=	C
1/4"	=	0.250"	=	D
5/16"	=	0.312"	=	E
3/8"	=	0.375"	=	F
7/16"	=	0.438"	=	G
1/2"	=	0.5"	=	H
9/16"	=	0.562"	=	J
5/8"	=	0.625"	=	K
11/16"	=	0.688"	=	L
3/4"	=	0.75"	=	M
13/16"	=	0.812"	=	N
7/8"	=	0.875"	=	P
15/16"	=	0.938"	=	R
1"	=	1"	=	S

Cast-In Heaters