

## PIPE CLAMP THERMOCOUPLES

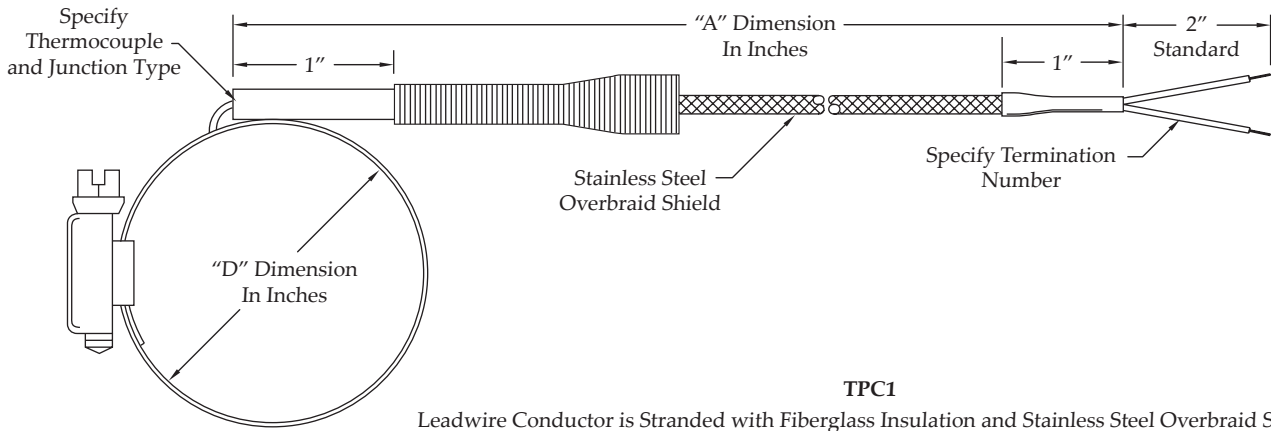

### "D" Dimension Options

Termination Number	Description
N	1/2" to 7/8"
1	7/8" to 1 1/4"
2	1 1/4" to 2 1/4"
3	2 3/4" to 3 5/16"
4	3 1/4" to 4 1/4"
5	4 1/4" to 5 1/4"

### Termination Options

Termination Number	Description
0	2" Split Leads
1	#6 Spade Lugs
3	Standard Plug

### Part Number Sequence

TPC1-JG-04230

See tables on page 54

TPC1	-	J	G	-	042	3	0
Sensor Type & Style No.		Thermocouple Type	Junction Type		"A" Dimension	"D" Dimension	Termination Option

## PIPE CLAMP ADAPTERS

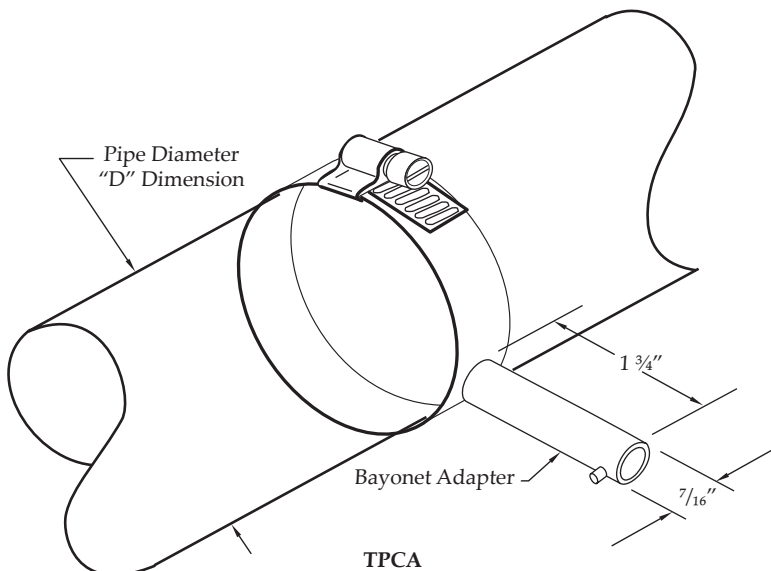

### "D" Dimension Options

Termination Number	Description
N	1/2" to 7/8"
1	7/8" to 1 1/4"
2	1 1/4" to 2 1/4"
3	2 3/4" to 3 5/16"
4	3 1/4" to 4 1/4"
5	4 1/4" to 5 1/4"

### Part Number Sequence TPCA-2

TPCA	-	2
Sensor Type & Style No.		"D" Dimension

## CODE DEFINITIONS AND TERMINATION TYPES

### Thermocouple Type

Thermocouple Type Codes				Limits of Error
E	J	K	T	Standard Limits
2	3	4	8	Special Limits

### Sheath Diameter

Code	Diameters
B	.125" or 1/8" O.D.
V	.156" or 5/32" O.D.
C	.188" or 3/16" O.D.
D	.250" or 1/4" O.D.
F	.375" or 3/8" O.D.

### Junction Type

Code	Single Junction
G	Grounded
U	Ungrounded

### Code Definitions

"L" Dimensions				"B" Dimensions				"A" Dimensions		Fractional Dimension Letter Code					
"L" dimensions are specified in whole inches and a single alpha character which represents a fraction. Enter the three digit code as follows: 3"      030      10 5/8"      10K				"B" dimensions are specified in fractions from 1/8" to 1". Use the single alpha character to indicate the tip length. Enter the code as follows: 1/8"    B      5/8"      K 1/4"    D      3/4"      M 3/8"    F      7/8"      P 1/2"    H      1"        S				"A" dimensions are specified in whole inches only. Enter the three digit code as follows: 9"        009 12"       012 36"       036 144"      144		1/16"	A	11/16"	L		
										1/8"	B	3/4"	M		
4 1/2"	04H	12"	120	3/16"	C	13/16"	N	1/4"	D	7/8"	P	5/16"	E	15/16"	R
6 1/4"	06D	15 3/8"	15F	3/8"	F	7/8"	P	36"	036	9/16"	J	3/8"	F	1"	S
7 7/8"	07P	17 3/4"	17M	1/2"	H	1"	S	144"	144	5/8"	K	7/16"	G	0	No
9 5/8"	09K	22 1/8"	22B							1/2"	H	Fraction			

### Termination Type Numbers

